

Ultracompact, Ultrathin Photoelectric Sensor with Built-in Amplifier

E3T



The Improved E3T Series with Easier, Smoother Mounting and Installation





- The series includes Through-beam, Long-distance (2 m) Sensors (E3T-ST3□).
- Easy installation with M3-mounting Sensors (E3T-ST□□M, E3T-FD□□M, and E3T-SL□□M).
- Small Cylindrical Sensors for one-point mounting are also available (E3T-C□□□(S)).
- Infrared Sensors added to the Series (E3T-□□□□(M)F).



 Be sure to read *Safety Precautions* on page 15.

For the most recent information on models that have been certified for safety standards, refer to your OMRON website.

Lineup Overview

Appearance		Sensing method	Through-beam	Retro-reflective	Diffuse-reflective	Limited-reflective	BGS-reflective
Rectangular type	Side-view 	M2-mounting	●	●	---	●	---
		M3-mounting	●	---	---	●	---
	Flat 	M2-mounting	●	---	●	---	●
		M3-mounting	---	---	●	---	---
Cylindrical type	Top-view 	---	●	---	●	---	---
	Side-view 	---	●	---	---	---	---

E3T

Ordering Information

Sensors [Refer to Dimensions on page 16.]

■ Red light □ Infrared light

M2-mounting Sensors A set of mounting screws is included with the Sensor.

Sensing method	Appearance	Sensing distance	Operation mode	Model	
				NPN output	PNP output
Through-beam (Emitter + Receiver) ^{*1}		2 m (Sensitivity Adjustment Unit can be used.)	Light-ON	E3T-ST31 2M ^{*4}	E3T-ST33 2M ^{*4}
			Dark-ON	E3T-ST32 2M ^{*4}	E3T-ST34 2M ^{*4}
		1 m (Sensitivity Adjustment Unit can be used.)	Light-ON	E3T-ST11 2M ^{*4}	E3T-ST13 2M ^{*4}
			Dark-ON	E3T-ST12 2M ^{*4}	E3T-ST14 2M ^{*4}
		300 mm	Light-ON	E3T-ST21 2M	E3T-ST23 2M
			Dark-ON	E3T-ST22 2M	E3T-ST24 2M
		2 m	Light-ON	E3T-ST31F 2M	E3T-ST33F 2M
			Dark-ON	E3T-ST32F 2M	E3T-ST34F 2M
		1 m	Light-ON	E3T-ST11F 2M	E3T-ST13F 2M
			Dark-ON	E3T-ST12F 2M	E3T-ST14F 2M
	300 mm	Light-ON	E3T-ST21F 2M	E3T-ST23F 2M	
		Dark-ON	E3T-ST22F 2M	E3T-ST24F 2M	
		500 mm	Light-ON	E3T-FT11 2M ^{*4}	E3T-FT13 2M ^{*4}
			Dark-ON	E3T-FT12 2M ^{*4}	E3T-FT14 2M ^{*4}
		300 mm	Light-ON	E3T-FT21 2M	E3T-FT23 2M
			Dark-ON	E3T-FT22 2M	E3T-FT24 2M
		500 mm	Light-ON	E3T-FT11F 2M	E3T-FT13F 2M
			Dark-ON	E3T-FT12F 2M	E3T-FT14F 2M
		300 mm	Light-ON	E3T-FT21F 2M	E3T-FT23F 2M
			Dark-ON	E3T-FT22F 2M	E3T-FT24F 2M
Retro-reflective		Using the E39-R4 Reflector, provided 200 mm [30 mm] ^{*2}	Light-ON	E3T-SR41 2M ^{*3,4}	E3T-SR43 2M ^{*3,4}
			Dark-ON	E3T-SR42 2M ^{*3,4}	E3T-SR44 2M ^{*3,4}
Diffuse-reflective		5 to 30 mm	Light-ON	E3T-FD11 2M ^{*4}	E3T-FD13 2M ^{*4}
			Dark-ON	E3T-FD12 2M ^{*4}	E3T-FD14 2M ^{*4}
Limited-reflective		5 to 15 mm	Light-ON	E3T-SL11 2M ^{*4}	E3T-SL13 2M ^{*4}
			Dark-ON	E3T-SL12 2M ^{*4}	E3T-SL14 2M ^{*4}
		5 to 30 mm	Light-ON	E3T-SL21 2M ^{*4}	E3T-SL23 2M ^{*4}
			Dark-ON	E3T-SL22 2M ^{*4}	E3T-SL24 2M ^{*4}
BGS-reflective		1 to 15 mm	Light-ON	E3T-FL11 2M ^{*4}	E3T-FL13 2M ^{*4}
			Dark-ON	E3T-FL12 2M ^{*4}	E3T-FL14 2M ^{*4}
		1 to 30 mm	Light-ON	E3T-FL21 2M ^{*4}	E3T-FL23 2M ^{*4}
			Dark-ON	E3T-FL22 2M ^{*4}	E3T-FL24 2M ^{*4}

M3-mounting Sensors A set of mounting screws is not included with the Sensor. Order a Screw Set separately if required.

Sensing method	Appearance	Sensing distance	Operation mode	Model	
				NPN output	PNP output
Through-beam (Emitter + Receiver) ^{*1}		1 m	Light-ON	E3T-ST11M 2M	E3T-ST13M 2M
			Dark-ON	E3T-ST12M 2M	E3T-ST14M 2M
		300 mm	Light-ON	E3T-ST21M 2M	E3T-ST23M 2M
			Dark-ON	E3T-ST22M 2M	E3T-ST24M 2M
		1 m	Light-ON	E3T-ST11MF 2M	E3T-ST13MF 2M
			Dark-ON	E3T-ST12MF 2M	E3T-ST14MF 2M
		300 mm	Light-ON	E3T-ST21MF 2M	E3T-ST23MF 2M
			Dark-ON	E3T-ST22MF 2M	E3T-ST24MF 2M
Diffuse-reflective		5 to 30 mm	Light-ON	E3T-FD11M 2M	E3T-FD13M 2M
			Dark-ON	E3T-FD12M 2M	E3T-FD14M 2M
Limited-reflective		5 to 15 mm	Light-ON	E3T-SL11M 2M	E3T-SL13M 2M
			Dark-ON	E3T-SL12M 2M	E3T-SL14M 2M
		5 to 30 mm	Light-ON	E3T-SL21M 2M	E3T-SL23M 2M
			Dark-ON	E3T-SL22M 2M	E3T-SL24M 2M

*1. The model number of the Emitter is expressed by adding an "L" to the set model number in the table. Example: E3T-ST11-L 2M
The model number of the Receiver is expressed by adding a "D" to the set model number in the table. Example: E3T-ST11-D 2M

*2. Values in parentheses indicate the minimum required distance between the Sensor and Reflector.



*3. Models are available either with or without the E39-R37-CA Reflector included.

Models with E39-R37-CA Reflector: E3T-SR4□-S

Models without Reflector: E3T-SR4□-C

*4. Models with robot (bending-resistant) cable are also available with "R" in the model number. (Example: E3T-ST11R 2M)

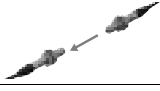
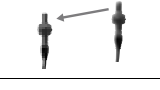
Small Cylindrical Sensors A set of mounting nuts is included with the Sensor.

Sensing method	Appearance	Sensing distance	Operation mode	Model	
				NPN output	PNP output
Through-beam (Emitter + Receiver)		1 m	Light-ON	---	---
			Dark-ON	E3T-CT12 2M	E3T-CT14 2M
		500 mm	Light-ON	---	---
			Dark-ON	E3T-CT22S 2M	E3T-CT24S 2M
Diffuse-reflective (with adjuster)		3 to 50 mm	Light-ON	E3T-CD11 2M	E3T-CD13 2M
			Dark-ON	---	---

Accessories (Order Separately)

Accessories for M2-mounting Sensors These accessories are not included with the Sensor. Order them separately if required.

Name	Applicable Sensor	Model	Quantity	Dimensions page	Remarks
Slit for Through-beam Side-view Sensors	0.5 dia.	E3T-ST3□□	2 (One each for Emitter and Receiver; common with Slit widths of 1 dia. and 0.5 dia.)	21	Sensing distance 200 mm, Minimum detectable object (reference value) 0.5-mm dia.
		E3T-ST1□□			Sensing distance 100 mm, Minimum detectable object (reference value) 0.5-mm dia.
		E3T-ST2□□			Sensing distance 30 mm, Minimum detectable object (reference value) 0.5-mm dia.
	1 dia.	E3T-ST3□□			Sensing distance 600 mm, Minimum detectable object (reference value) 1-mm dia.
		E3T-ST1□□			Sensing distance 300 mm, Minimum detectable object (reference value) 1-mm dia.
		E3T-ST2□□			Sensing distance 100 mm, Minimum detectable object (reference value) 1-mm dia.
Slit for Through-beam Flat Sensors	0.5 dia.	E3T-FT1□□	1	22	Sensing distance 50 mm, Minimum detectable object (reference value) 0.5-mm dia.
		E3T-FT2□□			Sensing distance 30 mm, Minimum detectable object (reference value) 0.5-mm dia.
	1 dia.	E3T-FT1□□			Sensing distance 100 mm, Minimum detectable object (reference value) 1-mm dia.
		E3T-FT2□□			Sensing distance 50 mm, Minimum detectable object (reference value) 1-mm dia.
Sensitivity Adjustment Unit for Through-beam Side-view Sensors with Red Light	E3T-ST3□	E39-E10	1	---	Sensing distance (reference value) 1,200 to 1,800 mm
	E3T-ST1□				Sensing distance (reference value) 300 to 800 mm
Mounting Brackets for Side-view Sensors *1	E3T-S□□□□	E39-L116	1	22	Nut plate provided
		E39-L117			
		E39-L118			
Mounting Brackets for Flat Sensors *1	E3T-F□□□□	E39-L119	1	23	---
		E39-L120			
Screw Set for Side-view Sensors *2*3	E3T-S□□□□	E39-L164	2 for each	---	Material: Iron (Same type as provided with the Sensor.) Contents: Set screws (M2×14), Hexagonal nuts
Screw Set for Flat Sensors *2*3	E3T-F□□□□	E39-L165	2 for each	---	Material: Iron (Same type as provided with the Sensor.) Contents: Set screws (M2×8), Hexagonal nuts
SUS Screw Set for Flat Sensors *2	E3T-F□□□□	E39-L172	2	---	Material: SUS304 Contents: Bolt with hexagonal hole (M2×6)
SUS Screw Set for Side-view Sensors *2	E3T-S□□□□	E39-L173	2 for each	---	Material: SUS304 Contents: Bolt with hexagonal hole (M2×12), Hexagonal nuts, Spring washers, Flat washers

*1. When using Through-beam Sensors (E3T-ST□□, E3T-FT□□), order one Bracket for the Emitter and one for the Receiver.

*2. Order two Sets, one for the Emitter and one for the Receiver, for Through-beam Sensors (E3T-ST□□ or E3T-FT□□).

This is the Screw Set for mounting the Sensor to the Mounting Bracket. Order this Set if you lose the screws. Do not use this Screw Set to mount the Mounting Bracket to the equipment.

*3. This is included with the Sensor.

Accessories for M3-mounting Sensors These accessories are not included with the Sensor. Order them separately if required.

Name	Applicable Sensor	Model	Quantity	Dimensions page	Remarks	
Slits for Through-beam Side-view Sensors	0.5 dia.	E3T-ST1□M□	2 (One each for Emitter and Receiver)	21	Sensing distance 100 mm, Minimum detectable object (reference value) 0.5-mm dia.	
		E3T-ST2□M□			Sensing distance 30 mm, Minimum detectable object (reference value) 0.5-mm dia.	
	1 dia.	E3T-ST1□M□			E39-S76B	Sensing distance 300 mm, Minimum detectable object (reference value) 1-mm dia.
		E3T-ST2□M□				Sensing distance 100 mm, Minimum detectable object (reference value) 1-mm dia.
Mounting Bracket for Side-view Sensors *1	E3T-S□□□M□	E39-L166	1	24	Nut plate provided	
Mounting Bracket for Flat Sensors	E3T-FD□□M	E39-L167			---	
Back-mounting Spacer for Flat Sensors		E39-L168			Use this Spacer when mounting a Flat Sensor (E3T-FD□□M) from the back.	
SUS Screw Set for Flat Sensors *2	E3T-FD□□M	E39-L170	2	---	Material: SUS304 Contents: Bolt with hexagonal hole (M3×6)	
SUS Screw Set for Side-view Sensors *2*3	E3T-S□□□M□	E39-L171	2 for each		Material: SUS304 Contents: Bolt with hexagonal hole (M3×15), Hexagonal nuts, Spring washers, Flat washers	

*1. When using Through-beam Sensors (E3T-ST□□M□), order one Bracket for the Emitter and one for the Receiver.

*2. This is the Screw Set for mounting the Sensor to the Mounting Bracket. Order this Set if you lose the screws. Do not use this Screw Set to mount the Mounting Bracket to the equipment.

*3. Order two Sets, one for the Emitter and one for the Receiver, for Through-beam Sensors (E3T-ST□□M□).

Accessories for Small Cylindrical Sensors

Name	Applicable Sensor	Model	Quantity	Dimensions Page	Remarks
SUS Nut Set for Through-beam Sensors *1	E3T-CT□□ E3T-CT□□S	E39-M5	4 (Hexagonal nuts), 2 (Toothed washers)	---	Material: SUS303 (Same type as provided with the Sensor.)
SUS Nut Set for Diffuse-reflective Sensors	E3T-CD□□	E39-M6	2 (Hexagonal nuts), 1 (Toothed washers)		
Adjustment Driver for Diffuse-reflective Sensors		E39-G17	1		This Driver is used to turn the sensitivity adjuster. Provided with E3T-CD□□

*1. This Nut Set is for the Emitter/Receiver. This is the Nut Set for mounting the Sensor. Order this Set if you lose the screws.



Accessories for All Sensors

Name	Applicable Sensor	Model	Quantity	Dimensions Page	Remarks
Small Reflectors (for Retro-reflective Sensors)	E3T-SR4□	E39-R4	1	20	Sensing distance 200 mm [30 mm] *1 Minimum detectable object 2-mm dia. Provided with the E3T-SR4□
	E3T-SR4□-S	E39-R37-CA *2			Sensing distance 100 mm [10 mm] *1 Minimum detectable object 2-mm dia. Provided with the E3T-SR4□-S
Tape Reflectors (for Retro-reflective Sensors)	E3T-SR4□-C	E39-RS1-CA *2		21	Sensing distance 100 mm [10 mm] *1 Minimum detectable object 2-mm dia. Use Tape Reflectors in combination with the E3T-SR4□-C, which does not come with a Reflector.
		E39-RS2-CA *2			
		E39-RS3-CA *2			



*1. Values in parentheses indicate the minimum required distance between the Sensor and Reflector.

*2. The E3T-SR4□ cannot be used with the E39-R37 or E39-RS1/2/3 (without CA) Tape Reflectors.
The E39-□-CA Reflector is for use only with the E3T-SR4□. It cannot be used with other Sensors.





Ratings and Specifications

Sensing method		Through-beam									
Appearance		Rectangular type (Side-view)						Rectangular type (Flat)			
Item											
NPN output	Light-ON	E3T-ST31	E3T-ST31F	E3T-ST11 E3T-ST11M	E3T-ST11F E3T-ST11MF	E3T-ST21 E3T-ST21M	E3T-ST21F E3T-ST21MF	E3T-FT11	E3T-FT11F	E3T-FT21	E3T-FT21F
	Dark-ON	E3T-ST32	E3T-ST32F	E3T-ST12 E3T-ST12M	E3T-ST12F E3T-ST12MF	E3T-ST22 E3T-ST22M	E3T-ST22F E3T-ST22MF	E3T-FT12	E3T-FT12F	E3T-FT22	E3T-FT22F
PNP output	Light-ON	E3T-ST33	E3T-ST33F	E3T-ST13 E3T-ST13M	E3T-ST13F E3T-ST13MF	E3T-ST23 E3T-ST23M	E3T-ST23F E3T-ST23MF	E3T-FT13	E3T-FT13F	E3T-FT23	E3T-FT23F
	Dark-ON	E3T-ST34	E3T-ST34F	E3T-ST14 E3T-ST14M	E3T-ST14F E3T-ST14MF	E3T-ST24 E3T-ST24M	E3T-ST24F E3T-ST24MF	E3T-FT14	E3T-FT14F	E3T-FT24	E3T-FT24F
Sensing distance		2 m		1 m		300 mm		500 mm		300 mm	
Standard sensing object		Opaque, 3-mm dia. min.		Opaque, 2-mm dia. min.				Opaque, 1.3-mm dia. min.			
Minimum detectable object (reference value)		Opaque, 3-mm dia.		Opaque, 2-mm dia.				Opaque, 1.3-mm dia.			
Hysteresis (white paper)		---									
Black/white error		---									
Directional angle		Emitter: 2° to 20° Receiver: 2° to 70°						Emitter: 3° to 25° Receiver: 3° min.			
Light source (wavelength)		Red LED (650 nm)	Infrared LED (860 nm)	Red LED (650 nm)	Infrared LED (860 nm)	Red LED (650 nm)	Infrared LED (860 nm)	Red LED (650 nm)	Infrared LED (860 nm)	Red LED (650 nm)	Infrared LED (860 nm)
Power supply voltage		12 to 24 VDC ±10%, ripple (p-p) 10% max.									
Current consumption		30 mA max. (Emitter 10 mA max., Receiver 20 mA max.)									
Control output		Load power supply voltage: 26.4 VDC max. Load current: 50 mA max. (residual voltage: 2 V max. for load current of 10 to 50 mA, 1 V max. for load current of less than 10 mA) Open-collector output									
Indicators		Operation indicator (orange), Stability indicator (green)									
Protection circuits		Power supply and control output reverse polarity protection, Output short-circuit protection									
Response time		Operate or reset: 1 ms max.									
Ambient illumination		Incandescent lamp: 5,000 lx max., Sunlight: 10,000 lx max.									
Ambient temperature range		Operating: -25 to 55°C Storage: -40 to 70°C (with no icing or condensation)									
Ambient humidity range		Operating: 35% to 85% Storage: 35% to 95% (with no condensation)									
Insulation resistance		20 MΩ min. at 500 VDC									
Dielectric strength		AC1,000V, 50/60 Hz for 1 min.									
Vibration resistance (destruction)		10 to 2,000 Hz, 1.5-mm double amplitude or 300 m/s ² for 0.5 hours each in X, Y, and Z directions									
Shock resistance (destruction)		1,000 m/s ² 3 times each in X, Y, and Z directions									
Degree of protection		IEC 60529 IP67									
Connection method		Pre-wired (standard length: 2 m)									
Weight (packed state)		Approx. 40 g									
Materials	Case	PBT (polybutylene terephthalate)									
	Display window	Denatured polyarylate									
	Lens	Denatured polyarylate									
	Hexagonal nuts	---									
	Toothed washers	---									
Accessories *		Instruction manual, Set screws for mounting (Side-view Sensors: M2 × 14, Flat Sensors: M2 × 8), Nuts									

* Only the *Instruction Manual* is included with an M3-mounting Sensor (E3T-ST□□M(F)). Order the Set of Mounting Screws separately if required.

Sensing method Appearance		Through-beam		Retro-reflective (without M.S.R. function)
		Cylindrical type (Top-view)	Cylindrical type (Side-view)	Rectangular type (Side-view)
Item				
NPN output	Light-ON	---	---	E3T-SR41
	Dark-ON	E3T-CT12	E3T-CT22S	E3T-SR42
PNP output	Light-ON	---	---	E3T-SR43
	Dark-ON	E3T-CT14	E3T-CT24S	E3T-SR44
Sensing distance		1 m	500 mm	200 mm [30 mm] * (Using the E39-R4) 100 mm [10 mm] * (Using the E39-R37-CA)
Standard sensing object		Opaque, 4-mm dia. min.	Opaque, 5-mm dia. min.	Opaque, 27-mm dia. min.
Minimum detectable object (reference value)		---	---	2-mm dia. (Sensing distance 100 mm)
Hysteresis (white paper)		---	---	---
Black/white error		---	---	---
Directional angle		Receiver: 2°	Receiver: 10°	2° to 20°
Light source (wavelength)		Red LED (630 nm)	Red LED (625 nm)	Red LED (650 nm)
Power supply voltage		12 to 24 VDC ±10%, ripple (p-p) 10% max.		---
Current consumption		30 mA max. (Emitter 15 mA max., Receiver 15 mA max.)		20 mA max.
Control output		Load power supply voltage: 30 VDC max. Load current: 80 mA max. (residual voltage: 1 V max.) Open-collector output		Load power supply voltage: 26.4 VDC max. Load current: 50 mA max. (residual voltage: 2 V max. for load current of 10 to 50 mA, 1 V max. for load current of less than 10 mA) Open-collector output
Indicators		Operation indicator (orange), Stability indicator (green)		---
Protection circuits		Power supply reverse polarity protection, Output short-circuit protection		Power supply and control output reverse polarity protection, Output short-circuit protection, Mutual interference prevention
Response time		Operate or reset: 0.5 ms max.		Operate or reset: 1 ms max.
Ambient illumination		Incandescent lamp: 3,000 lx max.		Incandescent lamp: 5,000 lx max., Sunlight: 10,000 lx max.
Ambient temperature range		Operating: -25 to 55°C Storage: -30 to 70°C (with no icing or condensation)		Operating: -25 to 55°C Storage: -40 to 70°C (with no icing or condensation)
Ambient humidity range		Operating or Storage: 35% to 85% (with no condensation)		Operating: 35% to 85% Storage: 35% to 95% (with no condensation)
Insulation resistance		20 MΩ min. at 500 VDC		---
Dielectric strength		AC500V, 50/60 Hz for 1 min.		AC1,000V, 50/60 Hz for 1 min.
Vibration resistance (destruction)		10 to 55 Hz, 1.5-mm double amplitude for 2 hours each in X, Y, and Z directions		10 to 2,000 Hz, 1.5-mm double amplitude or 300 m/s ² for 0.5 hours each in X, Y, and Z directions
Shock resistance (destruction)		500 m/s ² 3 times each in X, Y, and Z directions		1,000m/s ² 3 times each in X, Y, and Z directions
Degree of protection		IEC 60529 IP65		IEC 60529 IP67
Connection method		Pre-wired (standard length: 2 m)		---
Weight (packed state)		Approx. 60 g		Approx. 20 g
Materials	Case	SUS303		PBT (polybutylene terephthalate)
	Display window	Polysulfone		Denatured polyarylate
	Lens	Polysulfone		Methacrylic resin
	Hexagonal nuts	SUS303		---
	Toothed washers	SUS303		---
Accessories		Instruction manual, Hexagonal nuts, Toothed washers		Instruction manual, Set screws for mounting (M2×14), Nuts, E39-R4 (E3T-SR4□ only), E39-R37-CA (E3T-SR4□-S only)

* Values in parentheses indicate the minimum required distance between the Sensor and Reflector.

Sensing method Appearance		Diffuse-reflective		Limited-reflective		BGS-reflective	
		Rectangular type (Flat)	Cylindrical type (Top-view)	Rectangular type (Side-view)		Rectangular type (Flat)	
Item							
NPN output	Light-ON	E3T-FD11 E3T-FD11M	E3T-CD11	E3T-SL11 E3T-SL11M	E3T-SL21 E3T-SL21M	E3T-FL11	E3T-FL21
	Dark-ON	E3T-FD12 E3T-FD12M	---	E3T-SL12 E3T-SL12M	E3T-SL22 E3T-SL22M	E3T-FL12	E3T-FL22
PNP output	Light-ON	E3T-FD13 E3T-FD13M	E3T-CD13	E3T-SL13 E3T-SL13M	E3T-SL23 E3T-SL23M	E3T-FL13	E3T-FL23
	Dark-ON	E3T-FD14 E3T-FD14M	---	E3T-SL14 E3T-SL14M	E3T-SL24 E3T-SL24M	E3T-FL14	E3T-FL24
Sensing distance		5 to 30 mm (50 × 50 mm white paper)	3 to 50 mm (100 × 100 mm white paper)	5 to 15 mm (50 × 50 mm white paper)	5 to 30 mm (50 × 50 mm white paper)	1 to 15 mm (50 × 50 mm white paper)	1 to 30 mm (50 × 50 mm white paper)
Standard sensing object		---					
Minimum detectable object (reference value)		0.15-mm dia. (sensing distance 10 mm)	---	0.15-mm dia. (sensing distance 10 mm)		0.15-mm dia. non-glossy object (sensing distance 10 mm)	
Hysteresis (white paper)		6 mm max.	15% or less of the sensing distance	2 mm max.	6 mm max.	0.5 mm max.	2 mm max.
Black/white error		---					
Directional angle		---					
Light source (wavelength)		Red LED (650 nm)	Infrared LED (870 nm)	Red LED (650 nm)			
Power supply voltage		12 to 24 VDC ±10%, ripple (p-p) 10% max.					
Current consumption		20 mA max.					
Control output		Load power supply voltage: 26.4 VDC max. Load current: 50 mA max. (residual voltage: 2 V max. for load current of 10 to 50 mA, 1 V max. for load current of less than 10 mA) Open-collector output	Load power supply voltage: 30 VDC max. Load current: 80 mA max. (residual voltage: 1 V max.) Open-collector output	Load power supply voltage: 26.4 VDC max. Load current: 50 mA max. (residual voltage: 2 V max. for load current of 10 to 50 mA, 1 V max. for load current of less than 10 mA) Open-collector output			
Indicators		Operation indicator (orange), Stability indicator (green)					
Protection circuits		Power supply and control output reverse polarity protection, Output short-circuit protection, Mutual interference prevention	Power supply reverse polarity protection, Output short-circuit protection	Power supply and control output reverse polarity protection, Output short-circuit protection, Mutual interference prevention			
Response time		Operate or reset: 1 ms max.	Operate or reset: 0.5 ms max.	Operate or reset: 1 ms max.			
Ambient illumination		Incandescent lamp: 5,000 lx max., Sunlight: 10,000 lx max.	Incandescent lamp: 3,000 lx max.	Incandescent lamp: 5,000 lx max., Sunlight: 10,000 lx max.			
Ambient temperature range		Operating: -25 to 55°C Storage: -40 to 70°C (with no icing or condensation)	Operating: -25 to 55°C Storage: -30 to 70°C (with no icing or condensation)	Operating: -25 to 55°C Storage: -40 to 70°C (with no icing or condensation)			
Ambient humidity range		Operating: 35% to 85% Storage: 35% to 95% (with no condensation)	Operating or Storage: 35% to 85% (with no condensation)	Operating: 35% to 85% Storage: 35% to 95% (with no condensation)			
Insulation resistance		20 MΩ min. at 500 VDC					
Dielectric strength		1,000 VAC, 50/60 Hz for 1 min.	500 VAC, 50/60 Hz for 1 min.	1,000 VAC, 50/60 Hz for 1 min.			
Vibration resistance (destruction)		10 to 2,000 Hz, 1.5-mm double amplitude or 300 m/s ² for 0.5 hours each in X, Y, and Z directions	10 to 55Hz, 1.5-mm double amplitude for 2 hours each in X, Y, and Z directions	10 to 2,000 Hz, 1.5-mm double amplitude or 300 m/s ² for 0.5 hours each in X, Y, and Z directions			
Shock resistance (destruction)		1,000 m/s ² 3 times each in X, Y, and Z directions	500 m/s ² 3 times each in X, Y, and Z directions	1,000m/s ² 3 times each in X, Y, and Z directions			
Degree of protection		IEC 60529 IP67		IEC 60529 IP67			
Connection method		Pre-wired (standard length: 2 m)					
Weight (packed state)		Approx. 20 g	Approx. 40 g	Approx. 20 g			
Materials	Case	PBT (polybutylene terephthalate)	SUS303	PBT (polybutylene terephthalate)			
	Display window	Denatured polyarylate	Epoxy	Denatured polyarylate			
	Lens	Denatured polyarylate	Polysulfone	Denatured polyarylate			
	Hexagonal nuts	---	SUS303	---			
	Toothed washers	---	SUS303	---			
Accessories		Instruction manual, Set screws for mounting (M2 × 8), Nuts *	Instruction manual, Hexagonal nuts, Toothed washers, Adjustment driver	Instruction manual, Set screws for mounting (M2 × 14), Nuts *		Instruction manual, Set screws for mounting (M2 × 8), Nuts	

* Only the *Instruction Manual* is included with an M3-mounting Sensor (E3T-FD□□M or E3T-SL□□M). Order the Set of Mounting Screws separately if required.

E3T

Engineering Data (Reference Value)

M2-mounting and M3-mounting Sensors

Parallel Operating Range

Through-beam

E3T-ST3□ + E39-S63

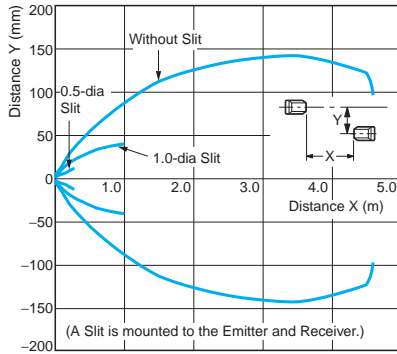

E3T-ST1□ + E39-S63

E3T-ST1□M + E39-S76A/S76B (Overall Diagram)

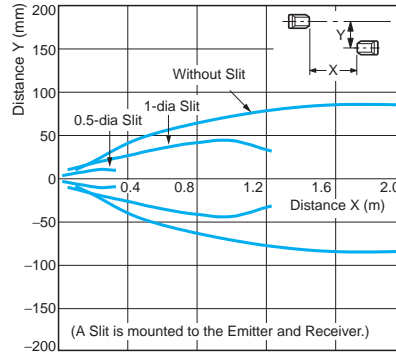

E3T-ST1□ + E39-S63

E3T-ST1□M + E39-S76A/S76B (Enlarged Diagram)

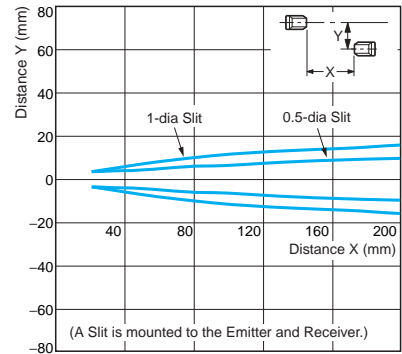

E3T-ST2□ + E39-S63

E3T-ST2□M + E39-S76A/S76B

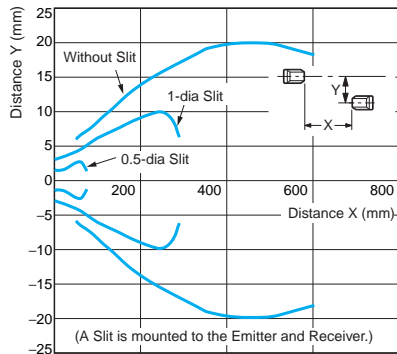

E3T-ST3□F + E39-S63

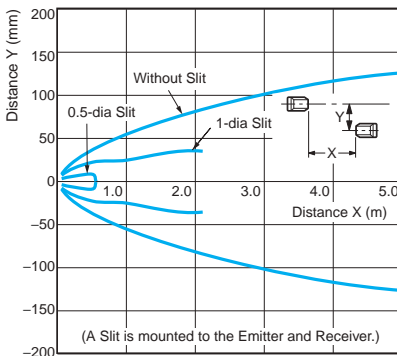

E3T-ST1□F + E39-S63

E3T-ST1□MF + E39-S76A/S76B (Overall Diagram)

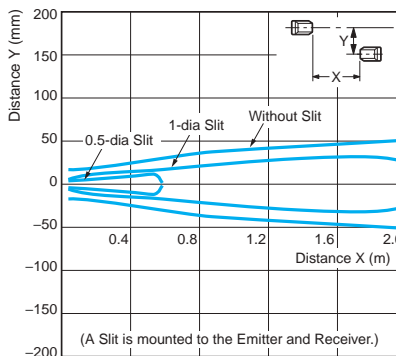

E3T-ST1□F + E39-S63

E3T-ST1□MF + E39-S76A/S76B (Enlarged Diagram)

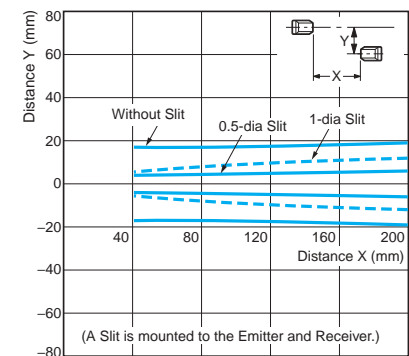

E3T-ST2□F + E39-S63

E3T-ST2□MF + E39-S76A/S76B

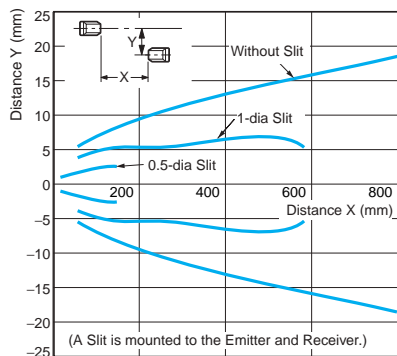

E3T-FT1□ + E39-S64 (Overall Diagram)

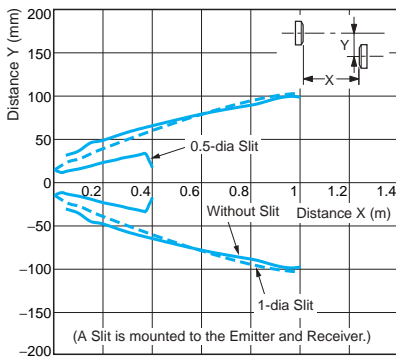

E3T-FT1□ + E39-S64 (Enlarged Diagram)

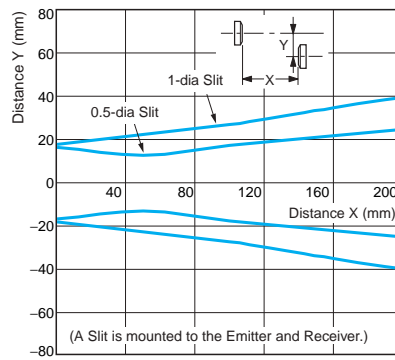

E3T-FT2□ + E39-S64

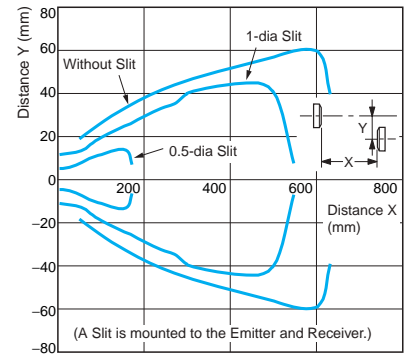

E3T-FT1□F + E39-S64 (Overall Diagram)

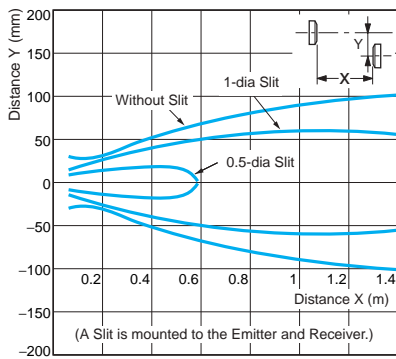

E3T-FT1□F + E39-S64 (Enlarged Diagram)

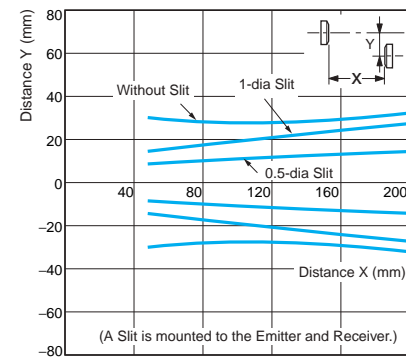

E3T-FT2□F + E39-S64

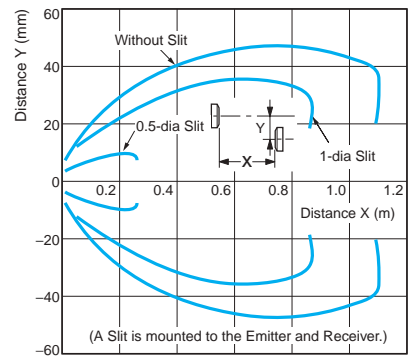

Retro-reflective

E3T-SR4□

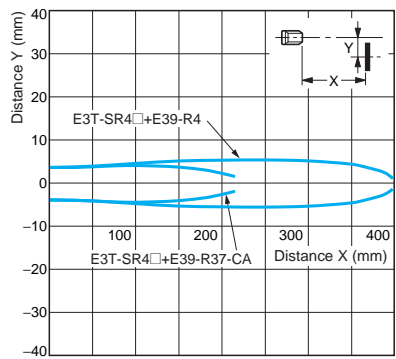

Operating Range

Limited-reflective

E3T-SL1□(M)

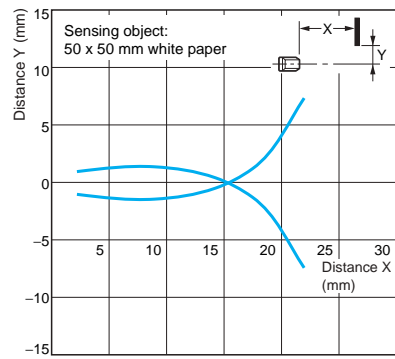

E3T-SL2□(M)

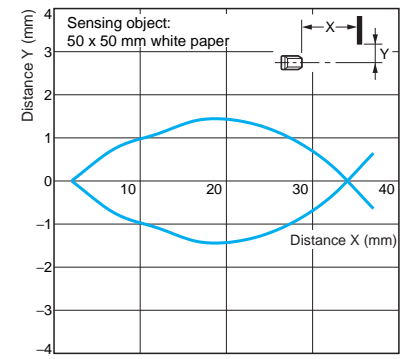

Diffuse-reflective

E3T-FD1□(M)

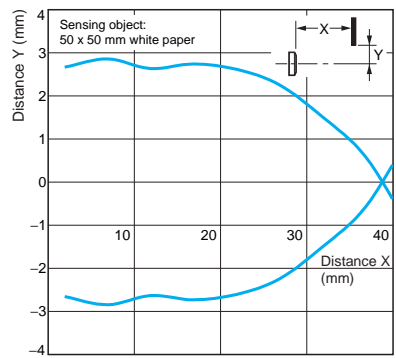

BGS-reflective

E3T-FL1□

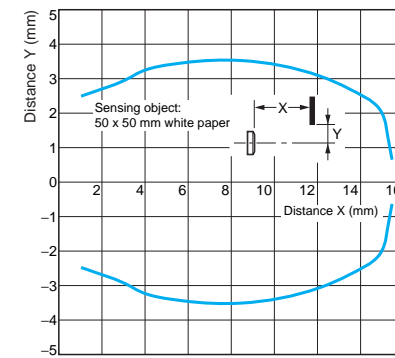

E3T-FL2□

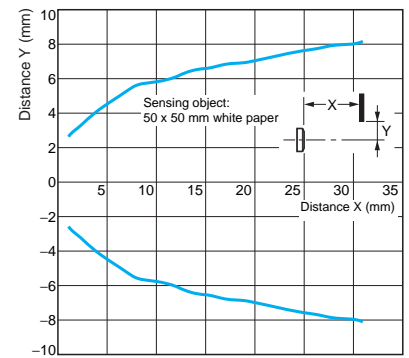

Inclination Detection Area Characteristic

Limited-reflective

E3T-SL1□(M) (Top to Bottom)

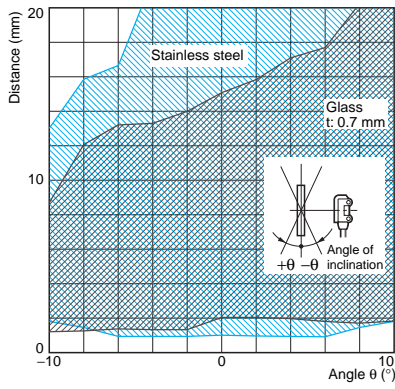

E3T-SL1□(M) (Right to Left)

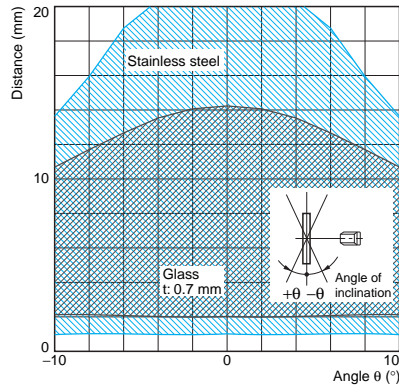

E3T-SL2□(M) (Top to Bottom)

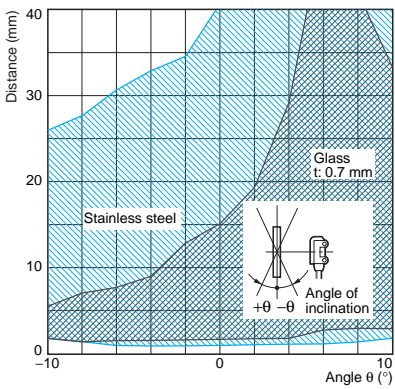

E3T-SL2□(M) (Right to Left)

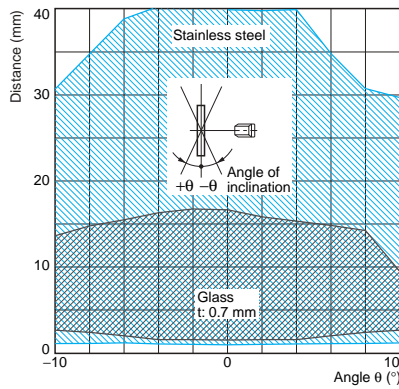

BGS-reflective

E3T-FL1□ (Top to Bottom)

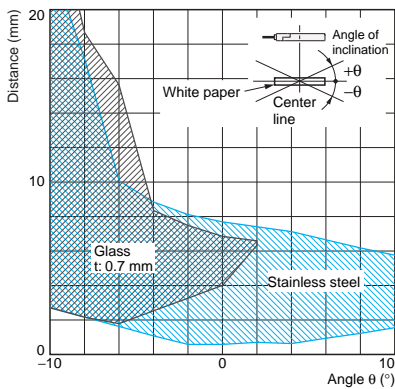

E3T-FL1□ (Right to Left)

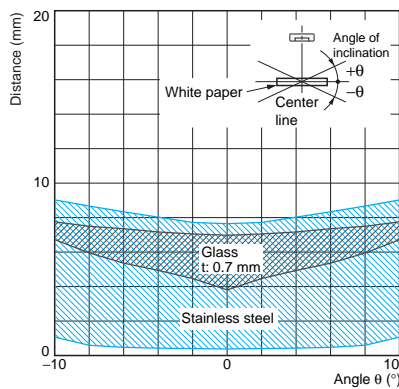

E3T-FL2□ (Top to Bottom)

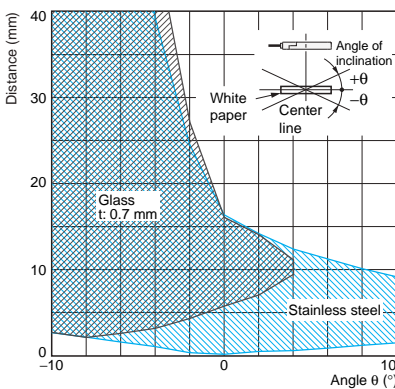

E3T-FL2□ (Right to Left)

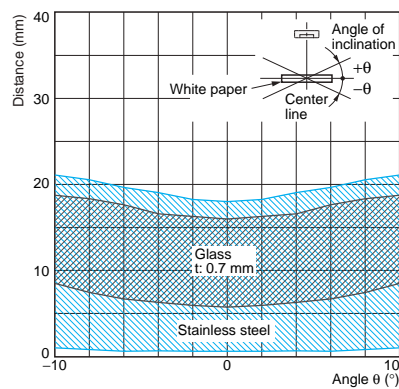

Excess Gain vs. Set Distance

Through-beam

E3T-ST3

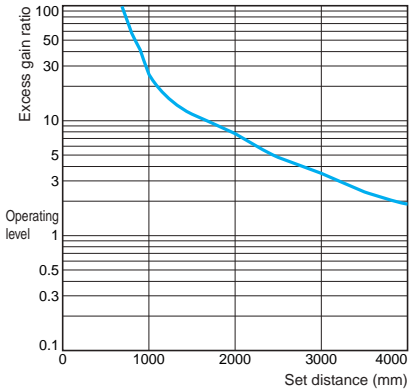

E3T-ST1(M)

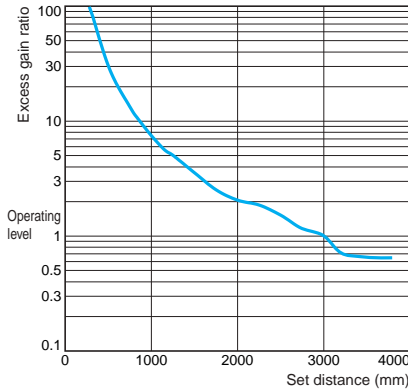

E3T-ST2(M)

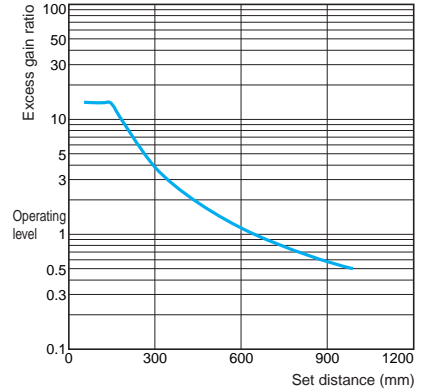

E3T-ST3(F)

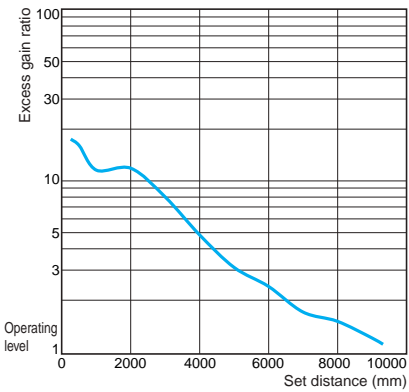

E3T-ST1(F)

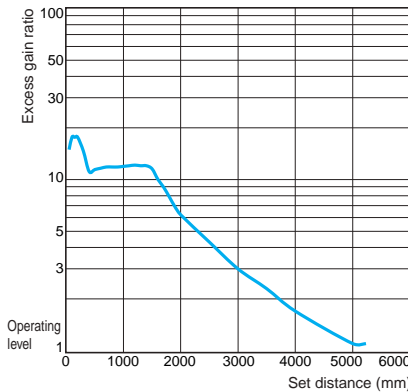

E3T-ST2(F)

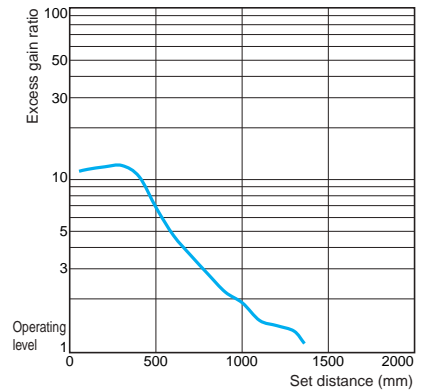

E3T-FT1

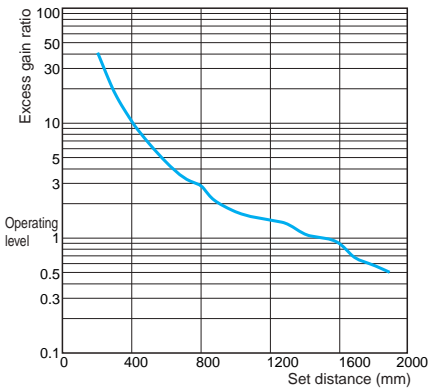

E3T-FT2

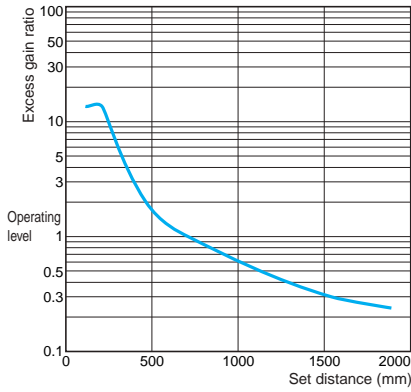

E3T-FT1(F)

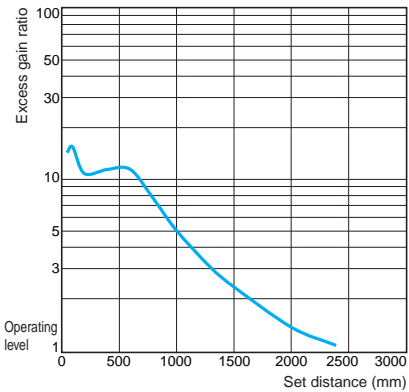

E3T-FT2(F)

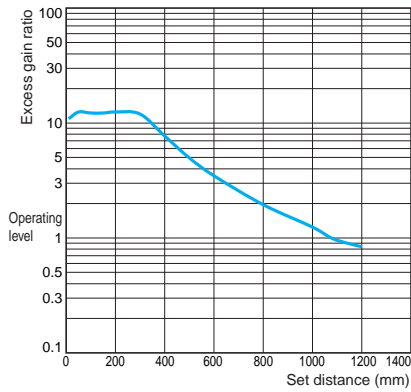

Retro-reflective

E3T-SR4□

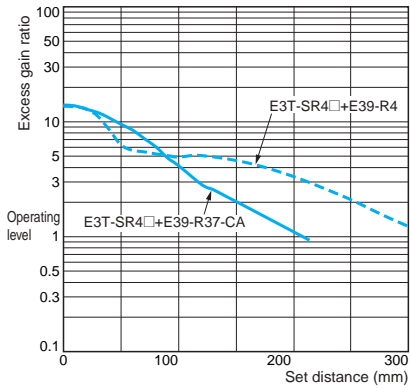

Diffuse-reflective

E3T-FD1□(M)

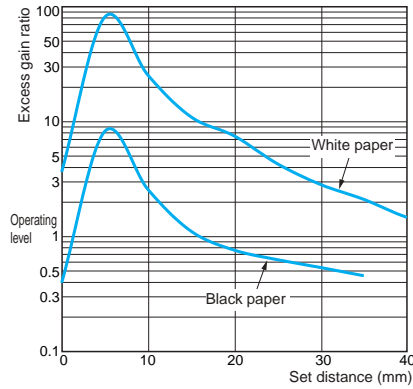

Limited-reflective

E3T-SL1□(M)

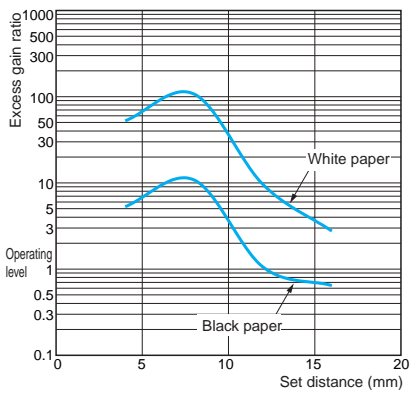

E3T-SL2□(M)

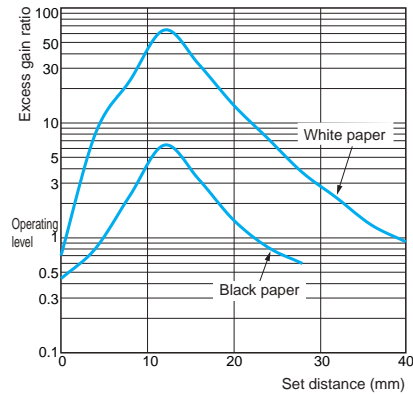

Sensing Object Size vs. Sensing Distance

Limited-reflective

E3T-SL1□(M)

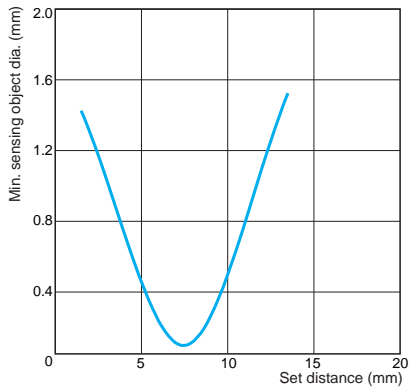

Diffuse/Limited-reflective

E3T-FD1□(M)/E3T-SL2□(M)

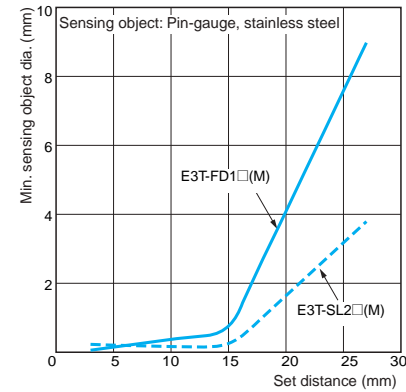

Sensing Distance Characteristics of Sensitivity Adjustment Unit (when Completing Optical Axis Adjustment)

E3T-ST1□ + E39-E10 Sensitivity Adjustment Unit

E3T-ST3□ + E39-E10 Sensitivity Adjustment Unit

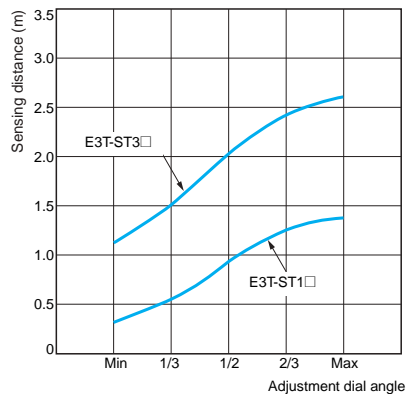

Sensing Distance vs. Material

Limited-reflective

E3T-SL1□(M)

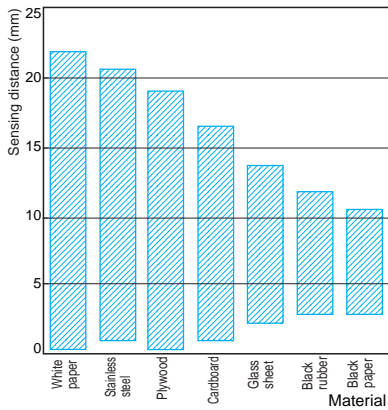

E3T-SL2□(M)

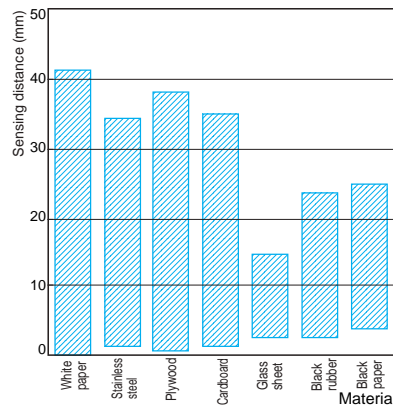

Diffuse-reflective

E3T-FD1□(M)

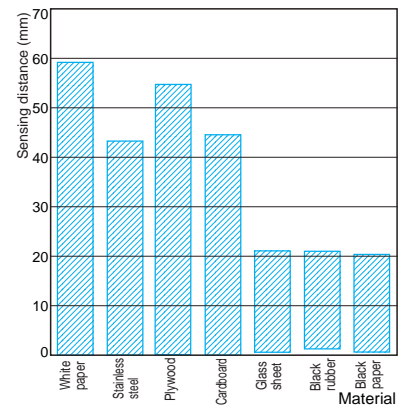

BGS-reflective

E3T-FL1□

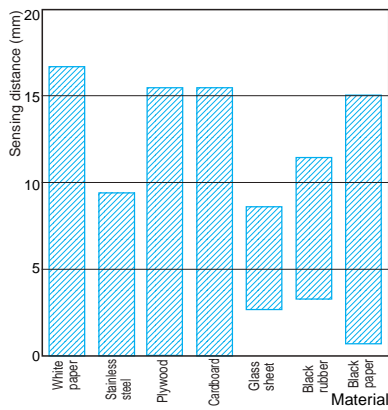

E3T-FL2□

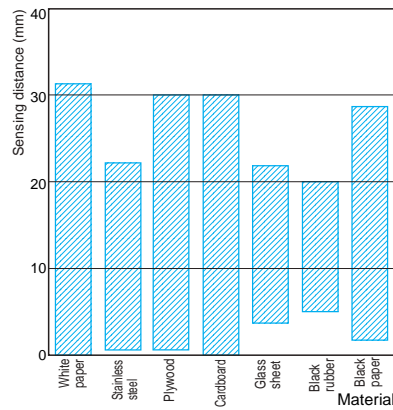

Small Cylindrical Sensors

Parallel Operating Range

Through-beam

E3T-CT1□

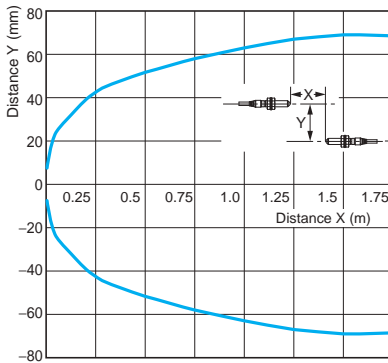

E3T-CT2□S (Top to Bottom)

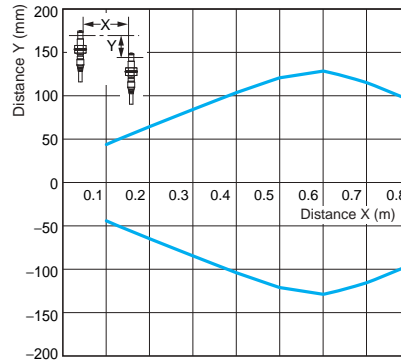

E3T-CT2□S (Right to Left)

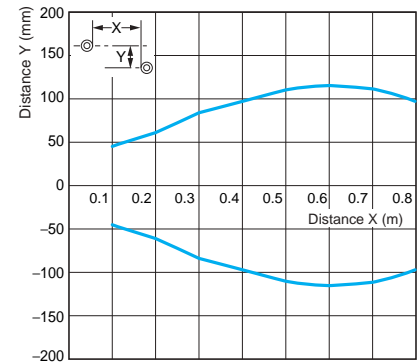

Operating Range

Diffuse-reflective

E3T-CD1□

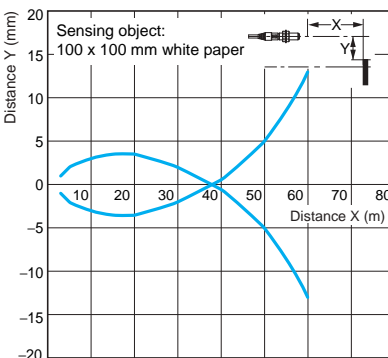

Sensing Distance vs. Material

Diffuse-reflective

E3T-CD1□

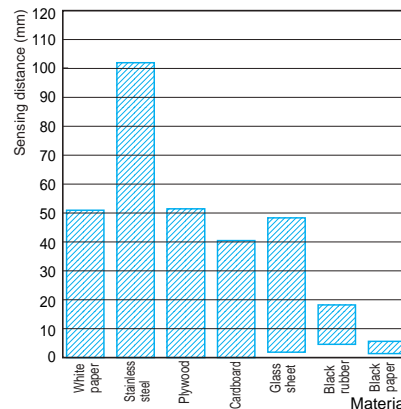

E3T

I/O Circuit Diagrams

NPN Output

Model	Operation mode	Timing charts	Output circuit
E3T-□□□1(F) E3T-□□□1M(F)	Light-ON	<p>Light incident Light interrupted</p> <p>Operation indicator (orange) ON OFF</p> <p>Output transistor ON OFF</p> <p>Load (e.g., relay) Operate Reset</p> <p>(Between brown (1) and black (4) leads)</p>	<p>Through-beam Receivers and Reflective Sensors</p> <p>Through-beam Emitters</p> <p>*1. There is no diode for Small Cylindrical Sensors (E3T-C□□□(S)). *2. This is 80 mA max. for Small Cylindrical Sensors (E3T-C□□□(S)).</p>
E3T-□□□2(F) E3T-□□□2M(F) E3T-□□□2S	Dark-ON	<p>Light incident Light interrupted</p> <p>Operation indicator (orange) ON OFF</p> <p>Output transistor ON OFF</p> <p>Load (e.g., relay) Operate Reset</p> <p>(Between brown (1) and black (4) leads)</p>	<p>Through-beam Receivers and Reflective Sensors</p> <p>Through-beam Emitters</p> <p>*1. There is no diode for Small Cylindrical Sensors (E3T-C□□□(S)). *2. This is 80 mA max. for Small Cylindrical Sensors (E3T-C□□□(S)).</p>

PNP Output

Model	Operation mode	Timing charts	Output circuit
E3T-□□□3(F) E3T-□□□3M(F)	Light-ON	<p>Light incident Light interrupted</p> <p>Operation indicator (orange) ON OFF</p> <p>Output transistor ON OFF</p> <p>Load (e.g., relay) Operate Reset</p> <p>(Between blue (3) and black (4) leads)</p>	<p>Through-beam Receivers and Reflective Sensors</p> <p>Through-beam Emitters</p> <p>*1. There is no diode for Small Cylindrical Sensors (E3T-C□□□(S)). *2. This is 80 mA max. for Small Cylindrical Sensors (E3T-C□□□(S)).</p>
E3T-□□□4(F) E3T-□□□4M(F) E3T-□□□4S	Dark-ON	<p>Light incident Light interrupted</p> <p>Operation indicator (orange) ON OFF</p> <p>Output transistor ON OFF</p> <p>Load (e.g., relay) Operate Reset</p> <p>(Between blue (3) and black (4) leads)</p>	<p>Through-beam Receivers and Reflective Sensors</p> <p>Through-beam Emitters</p> <p>*1. There is no diode for Small Cylindrical Sensors (E3T-C□□□(S)). *2. This is 80 mA max. for Small Cylindrical Sensors (E3T-C□□□(S)).</p>

Safety Precautions

Refer to *Warranty and Limitations of Liability*.

⚠ WARNING

This product is not designed or rated for ensuring safety of persons. Do not use it for such purpose.

Do not apply AC power to the E3T, otherwise the E3T may rupture.

Precautions for Correct Use

Do not use the product in atmospheres or environments that exceed product ratings.

● Wiring

The maximum power supply voltage is 26.4 VDC. Before turning the power ON, make sure that the power supply voltage is not more than maximum voltage.

Load short-circuit protection

The E3T incorporates a load short-circuit protection function. If the load short-circuits, the output of the E3T will be turned OFF. Then, recheck the wiring and turn on the E3T again to reset the load short-circuit protection function. The load short-circuit protection function will work if there is a current flow that is 1.5 times larger than the rated load current. When using a capacitance load, be sure that the inrush current will not exceed 1.5 times larger than the rated current.

● Mounting

When mounting the Sensor, never strike it with a heavy object, such as a hammer. Doing so may reduce its watertight properties. Use screws with spring, flat, or toothed washers to secure the Sensor. Tightening Torque

- M2-mounting Sensors: 0.15 N·m max
- M3-mounting Sensors: 0.5 N·m max
- Small Cylindrical Sensors: 1 N·m max

Attachment to Moving Parts

To mount the Photoelectric Sensor to a moving part, such as a robot hand, consider using a Sensor that uses a bending-resistant cable (robot cable).

● Adjusting

Indicators

- The following graphs indicate the status of each operating level.
- Be sure to use the E3T within the stable operating range.

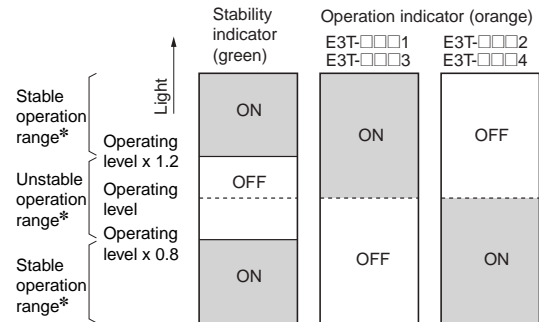

* If the E3T's operating level is set to the stable operation range, the E3T will be in most reliable operation without being influenced by temperature change, voltage fluctuation, dust, or setting change. If the operating level cannot be set to the stable operation range, pay attention to environmental changes while operating the E3T.

Use of E39-E10 Sensitivity Adjustment Unit

(Dark-ON: E3T-ST12)

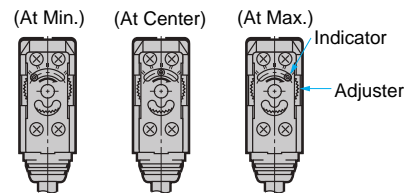

1. Mount the Unit on the Receiver.
2. Set the adjuster of the Sensitivity Adjustment Unit to Max. (Before shipping: Max.)
3. After mounting on the Sensor, adjust the optical axis and secure the Sensor.
4. Place a workpiece between the Emitter and Receiver and gradually turn the adjuster counterclockwise toward the Min. side. Stop turning the adjuster when the operation indicator and stability indicator (green) turn ON.
5. Remove the workpiece and confirm that the operation indicator is OFF and the stability indicator (green) is ON. This completes the adjustment.

Note: If the light attenuation rate due to a workpiece is 40% or less, the stability indicator will not turn ON whether or not light is received. When the variation of light is small such as when sensing semi-transparent workpieces, carefully perform preliminary testing.

E3T-CD□□ Sensitivity Adjustment

Use the special screwdriver that is provided with the Sensor to adjust the sensitivity. Do not exceed 0.8 N·cm when turning the adjuster.

● Others

Do not use the product under the following conditions.

- In the place exposed to the direct sunlight.
- In the place where humidity is high and condensation may occur.
- In the place where corrosive gas exists.
- In the place where vibration or shock is directly transmitted to the product.

E3T

Dimensions

(Unit: mm)

Tolerance class IT16 applies to dimensions in this datasheet unless otherwise specified.

Sensors

M2-mounting Sensors

Through-beam Side-view Sensors

E3T-ST1□(F) (Emitter)

E3T-ST2□(F) (Emitter)

E3T-ST3□(F) (Emitter)

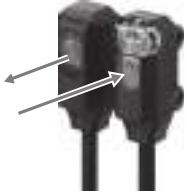

Emitter: E3T-ST□□(F)-L
Receiver: E3T-ST□□(F)-D

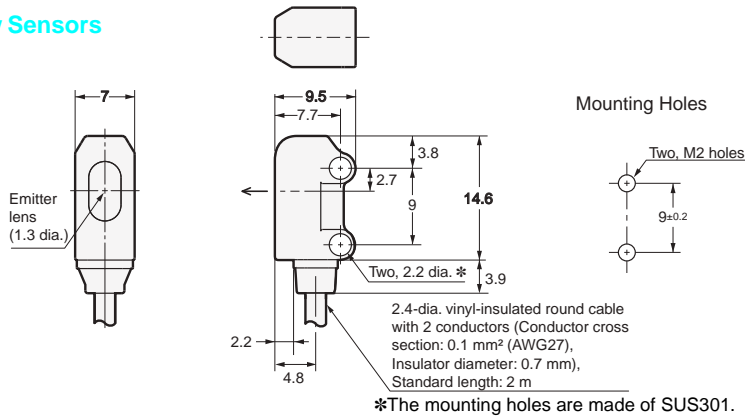

E3T-ST1□(F) (Receiver)

E3T-ST2□(F) (Receiver)

E3T-ST3□(F) (Receiver)

*The receiver lens diameters are given below.

Model	Receiver lens diameter
E3T-ST1□-D	(1.3 dia.)
E3T-ST2□-D	(1.3 dia.)
E3T-ST3□-D	(2.4 dia.)

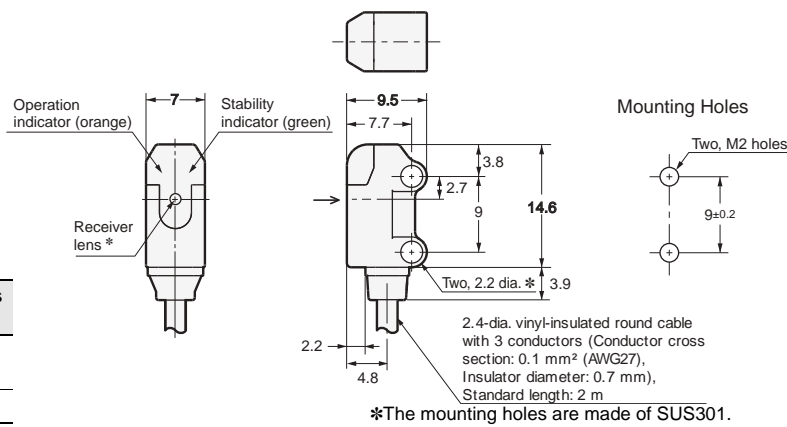

Through-beam Flat Sensors

E3T-FT1□(F) (Emitter)

E3T-FT2□(F) (Emitter)



Emitter: E3T-FT□□(F)-L
Receiver: E3T-FT□□(F)-D

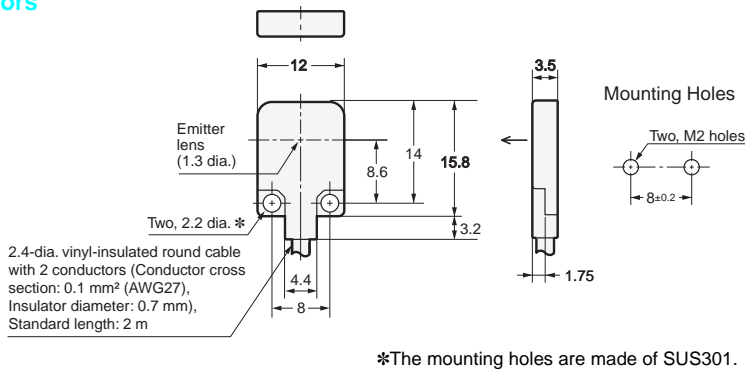

E3T-FT1□(F) (Receiver)

E3T-FT2□(F) (Receiver)

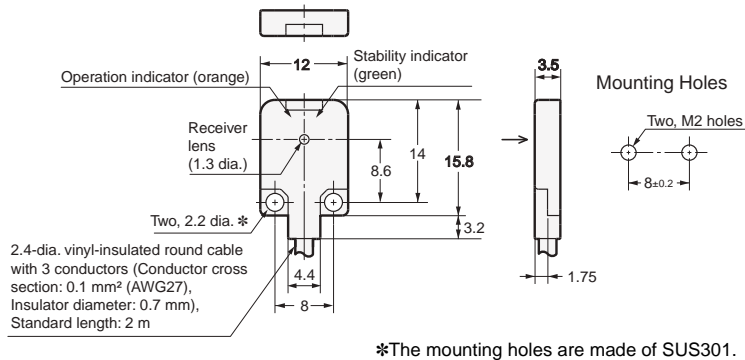

Retro-reflective Side-view Sensors

E3T-SR4□

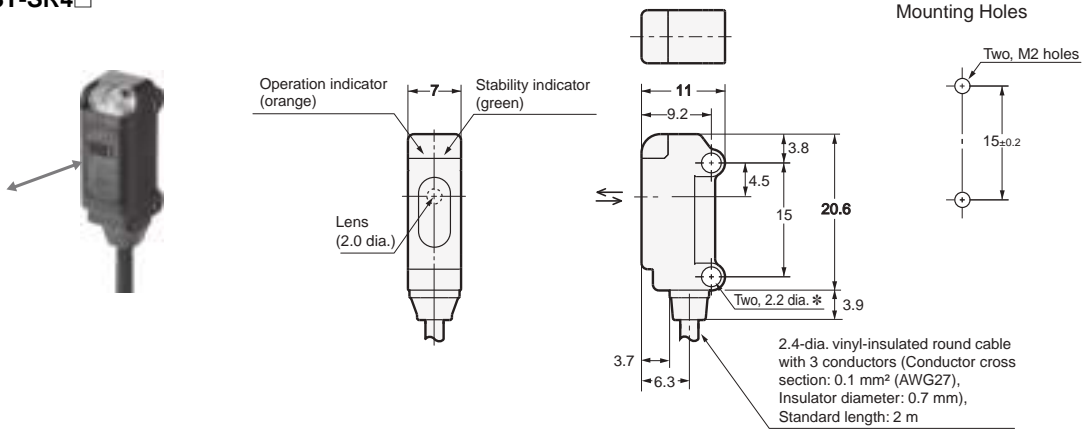

*The mounting holes are made of SUS301.

Diffuse-reflective Flat Sensors

E3T-FD1□

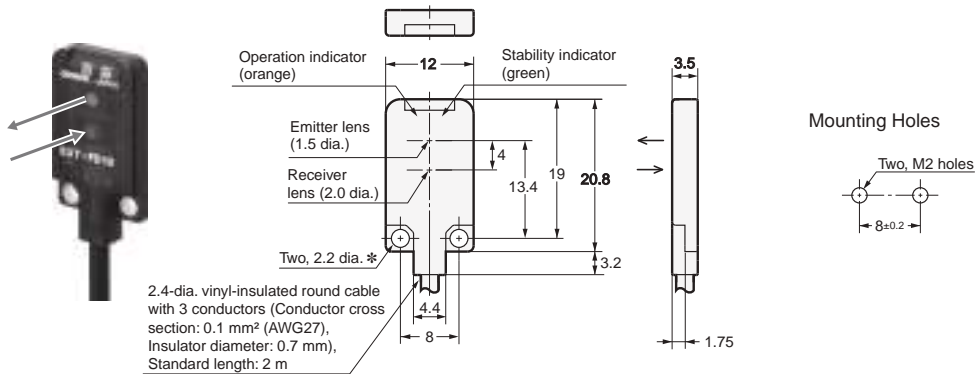

*The mounting holes are made of SUS301.

Limited-reflective Side-view Sensors

E3T-SL1□

E3T-SL2□

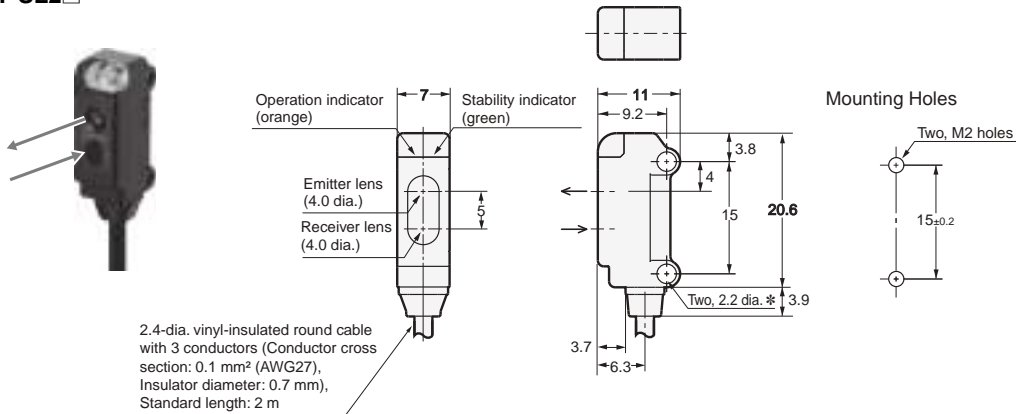

*The mounting holes are made of SUS301.

BGS-reflective Flat Sensors

- E3T-FL1□
- E3T-FL2□

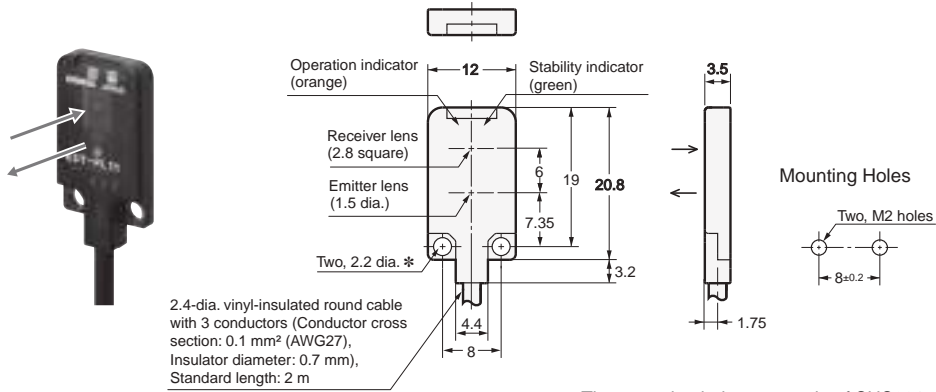

M3-mounting Sensors Through-beam Side-view Sensors

- E3T-ST1□M(F) (Emitter)
- E3T-ST2□M(F) (Emitter)

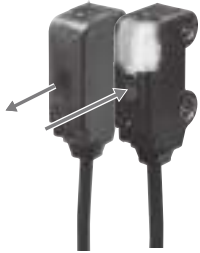

Emitter: E3T-ST□□(F)M-L
Receiver: E3T-ST□□(F)M-D

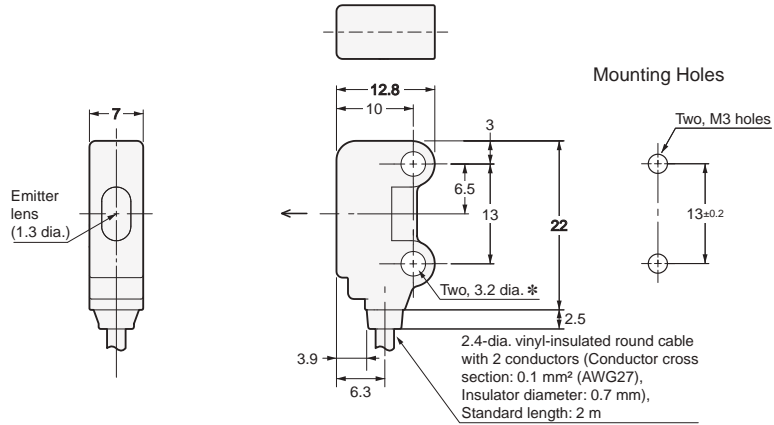

- E3T-ST1□M(F) (Receiver)
- E3T-ST2□M(F) (Receiver)

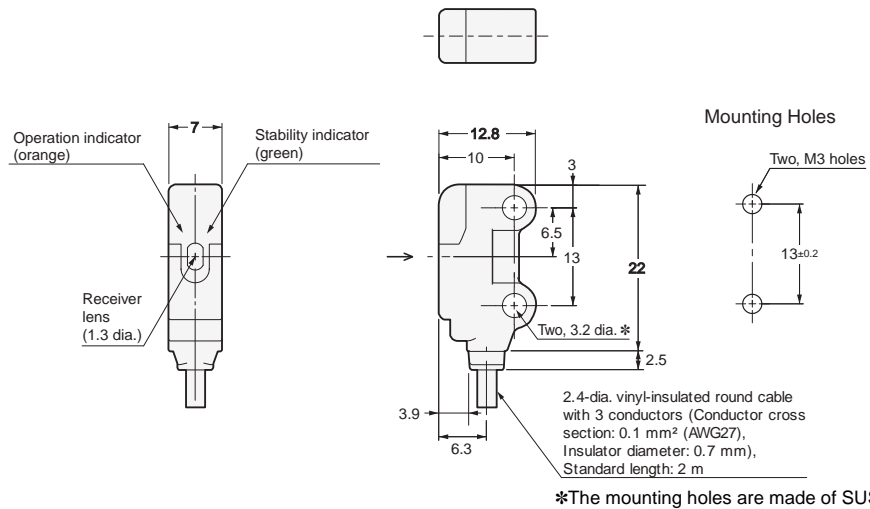

Diffuse-reflective Flat Sensors

E3T-FD1□M

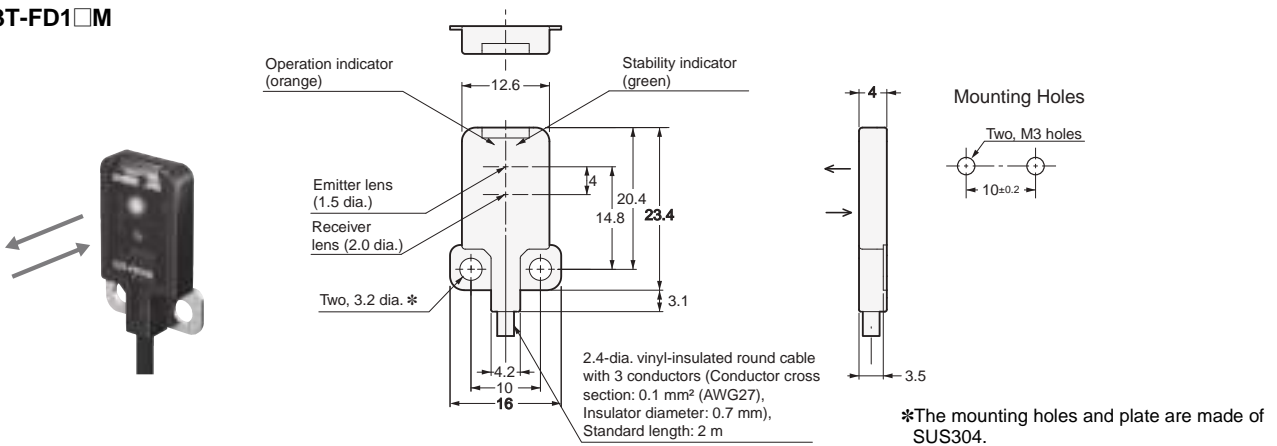

Limited-reflective Side-view Sensors

E3T-SL1□M

E3T-SL2□M

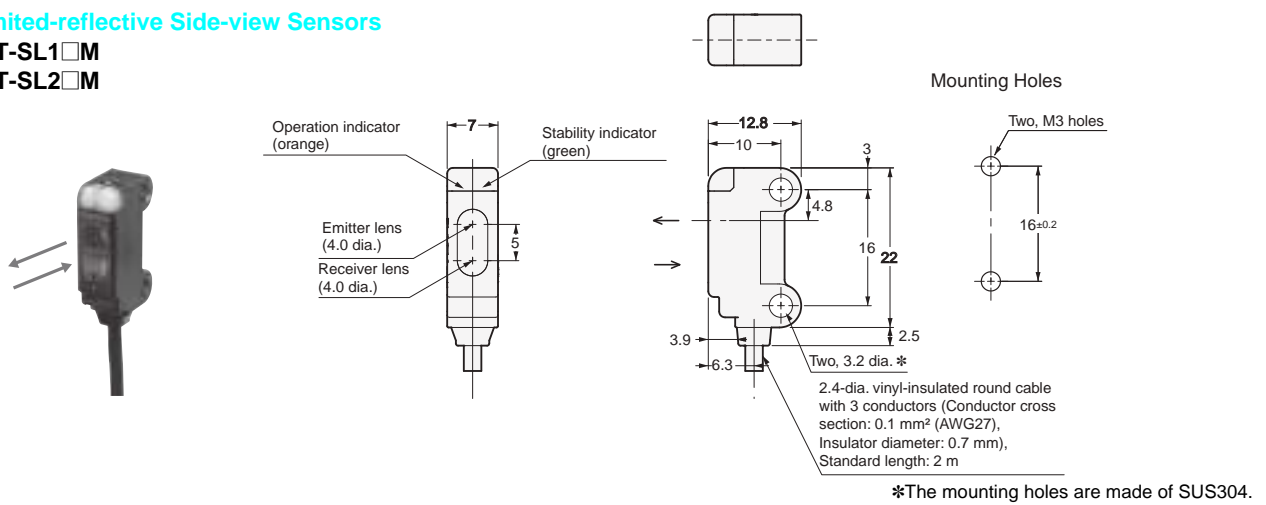

Small Cylindrical Sensors

Through-beam Top-view Sensors

E3T-CT1□ (Emitter)

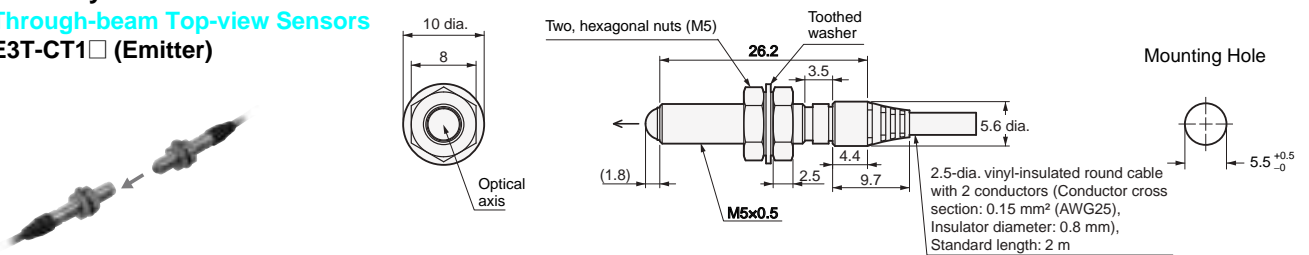

Emitter: E3T-CT1□-L
Receiver: E3T-CT1□-D

E3T-CT1□ (Receiver)

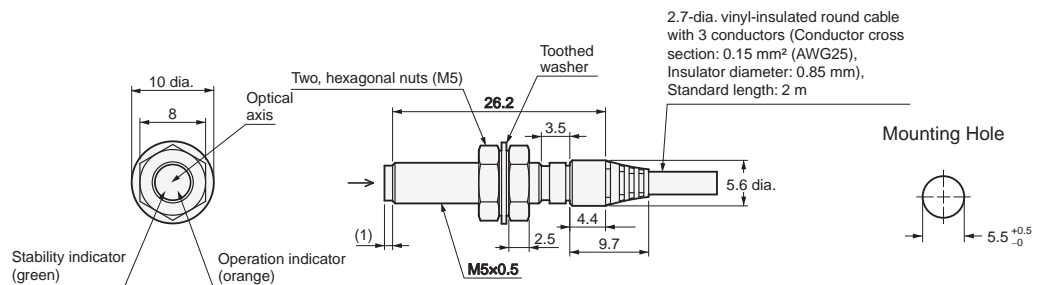

Through-beam Side-view Sensors

E3T-CT2□S (Emitter)

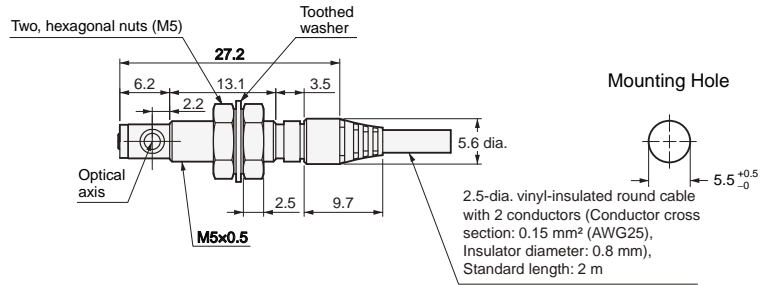
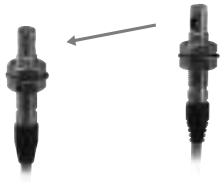

Emitter: E3T-CT2□S-L
Receiver: E3T-CT2□S-D

E3T-CT2□S (Receiver)

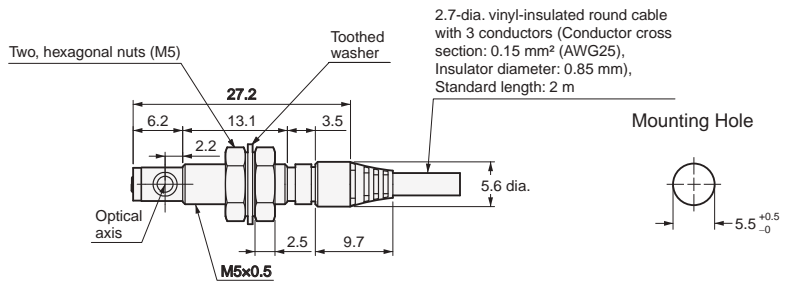
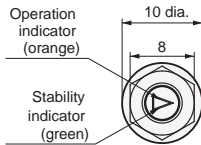

Diffuse-reflective Top-view Sensors

E3T-CD1□

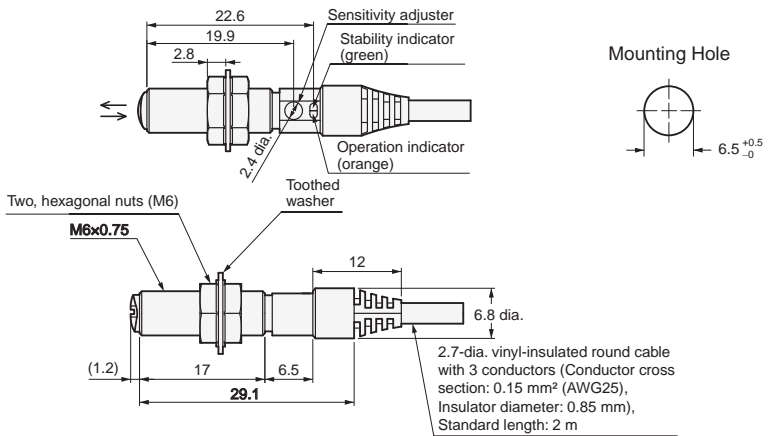
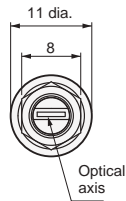

Accessories

Reflector (Provided with E3T-SR4□)

E39-R4



Material, reflective surface: acrylic
Rear surface: ABS

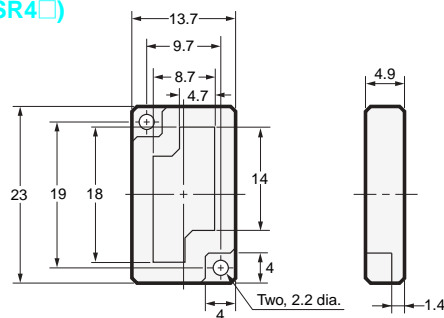

Reflector (Provided with E3T-SR4□-S)

E39-R37-CA



Material: Mounting plate: stainless steel (SUS301)
Reflective surface: acrylic

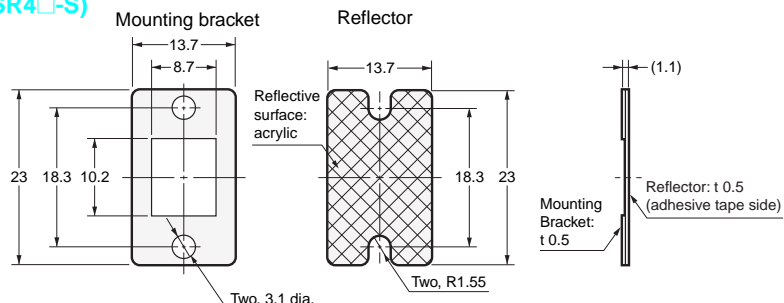

Note: The reflective plate and mounting plate (1) come as a set.

Accessories (Order Separately)

Tape Reflectors

E39-RS1-CA

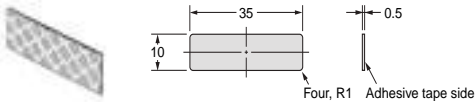

Material: Acrylic

E39-RS2-CA

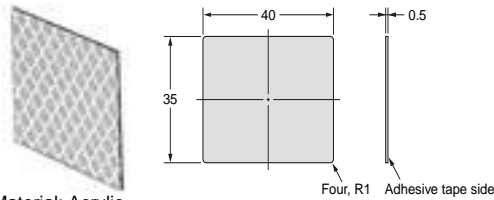

Material: Acrylic

E39-RS3-CA

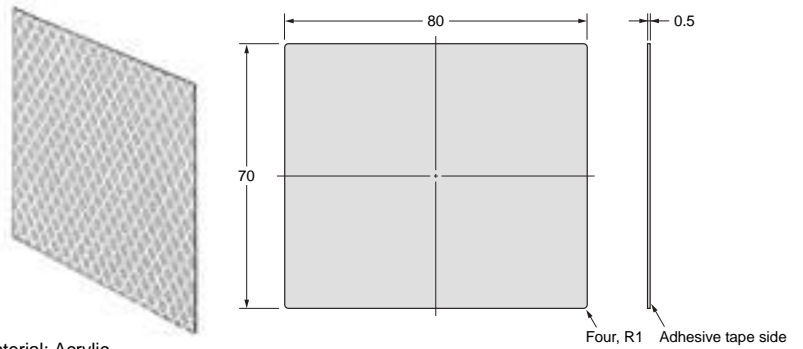

Material: Acrylic

Slit for E3T-ST□□(F) Through-beam Sensors

E39-S63

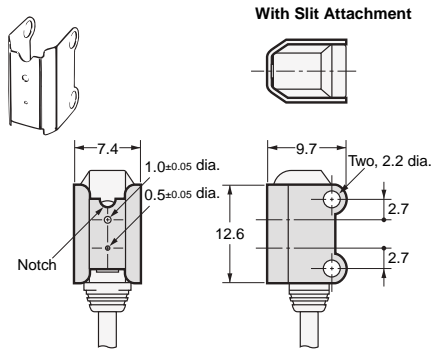

Material: 0.2-mm thick stainless steel (SUS301)

Note: Align the notch direction of the Slit when installing on the Emitter and Receiver.

Slit for E3T-FT□□(F) Through-beam Sensors

E39-S64

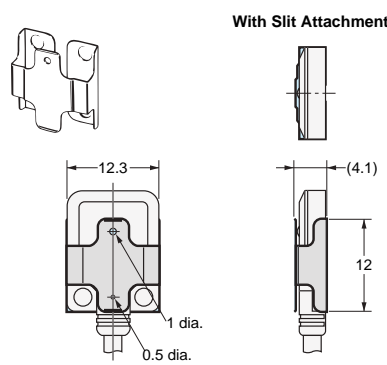

Material: 0.1-mm thick stainless steel (SUS301)

0.5-dia Slit for E3T-ST□□M(F) Through-beam Sensors

E39-S76A

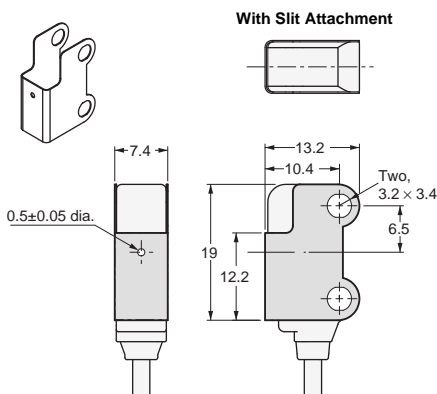

Material: 0.2-mm thick stainless steel (SUS301)

1-dia Slit for E3T-ST□□M(F) Through-beam Sensors

E39-S76B

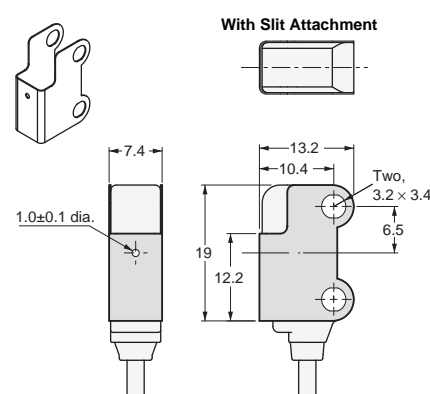

Material: 0.2-mm thick stainless steel (SUS301)

Sensitivity Adjustment Unit for E3T-ST1□/ST3□ Through-beam Sensors

E39-E10

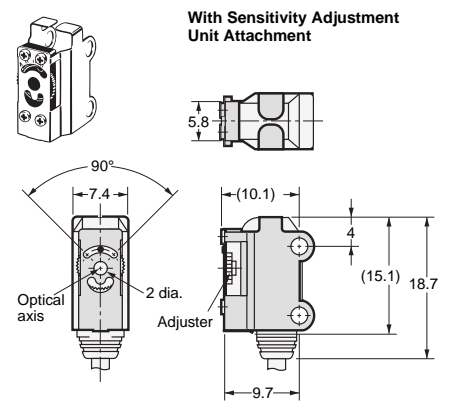

Material: stainless steel (SUS301)

Mounting Bracket for M2-mounting Side-view Sensors

E39-L116



Material: 1.2-mm-thick stainless steel (SUS304)

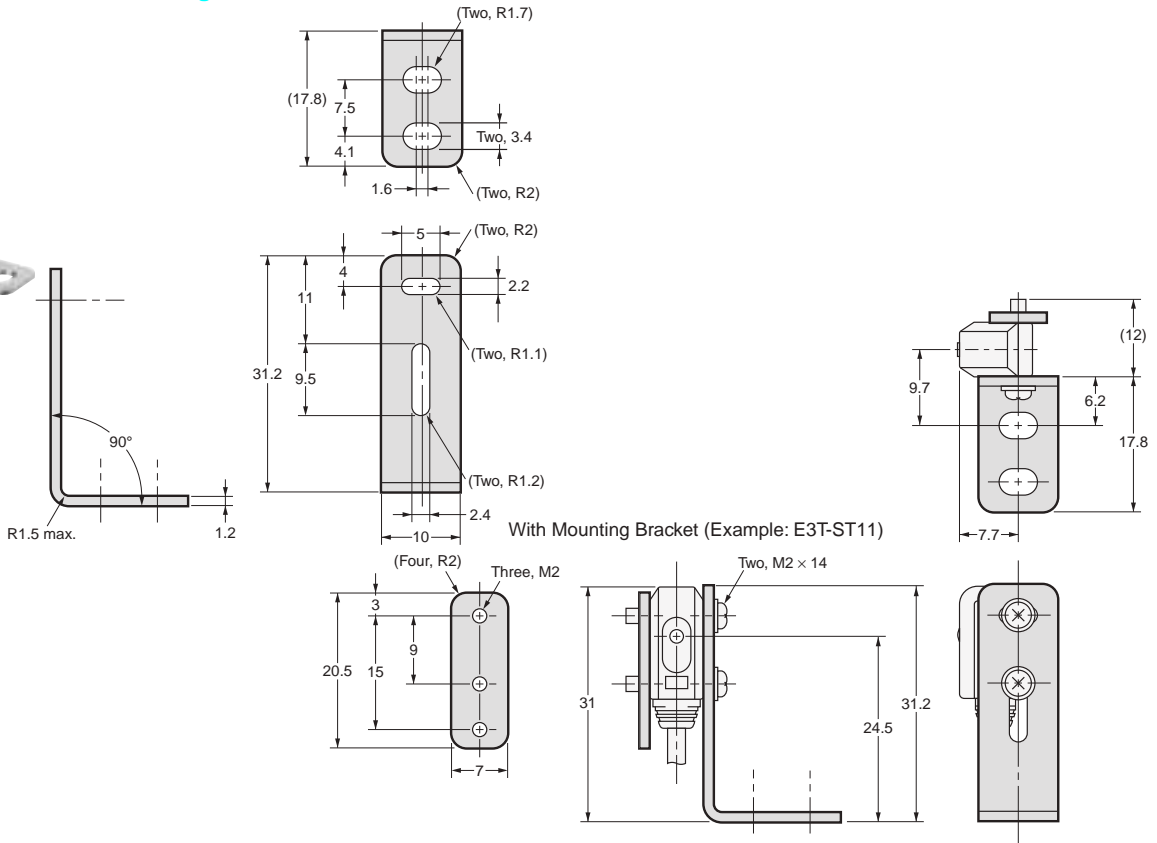

Mounting Bracket for M2-mounting Side-view Sensors

E39-L117



Material: 1.2-mm-thick stainless steel (SUS304)

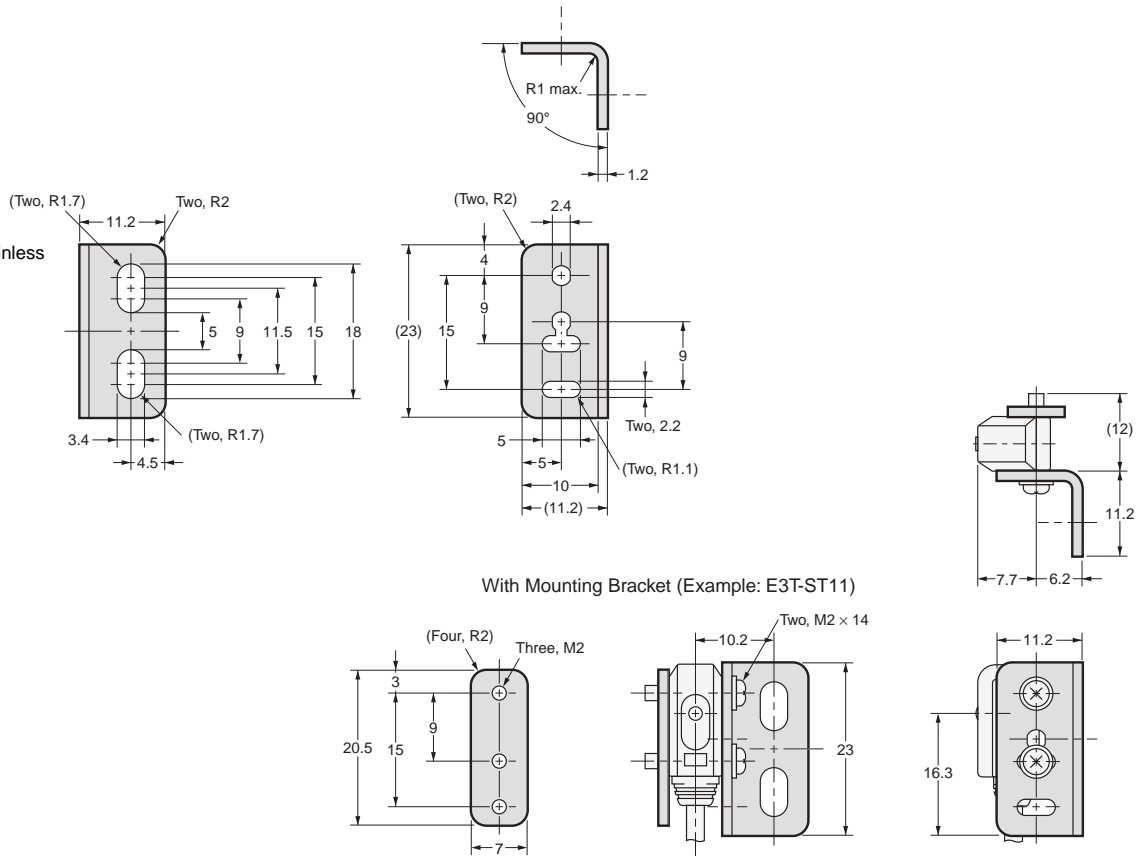

Mounting Bracket for M2-mounting Side-view Sensors

E39-L118



Material: 1.2-mm-thick stainless steel (SUS304)

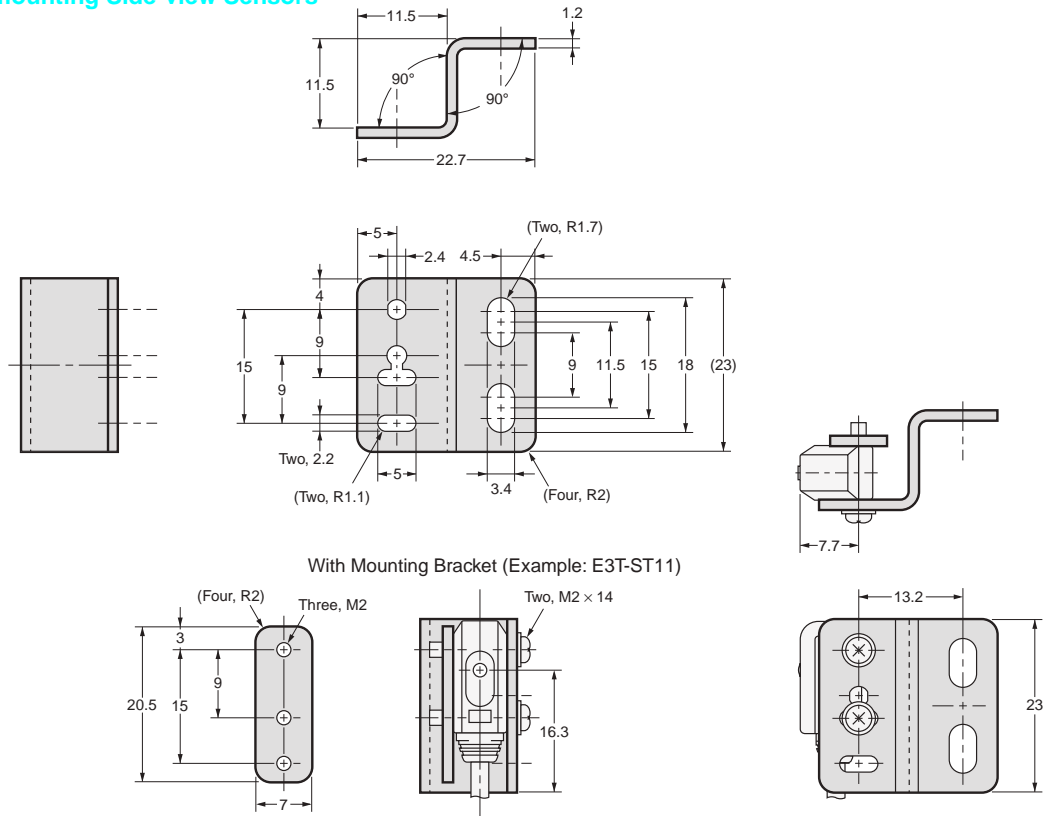

Mounting Bracket for M2-mounting Flat Sensors

E39-L119



Material: 1.2-mm-thick stainless steel (SUS304)

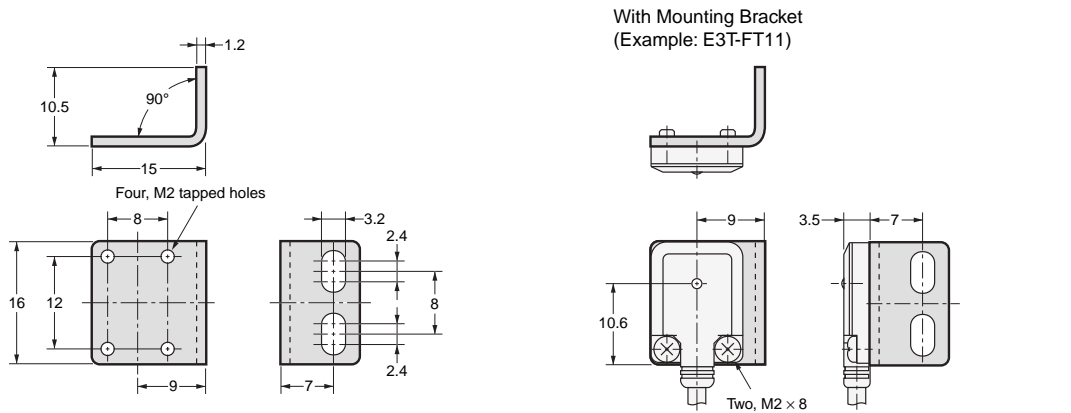

Mounting Bracket for M2-mounting Flat Sensors

E39-L120



Material: 1.2-mm-thick stainless steel (SUS304)

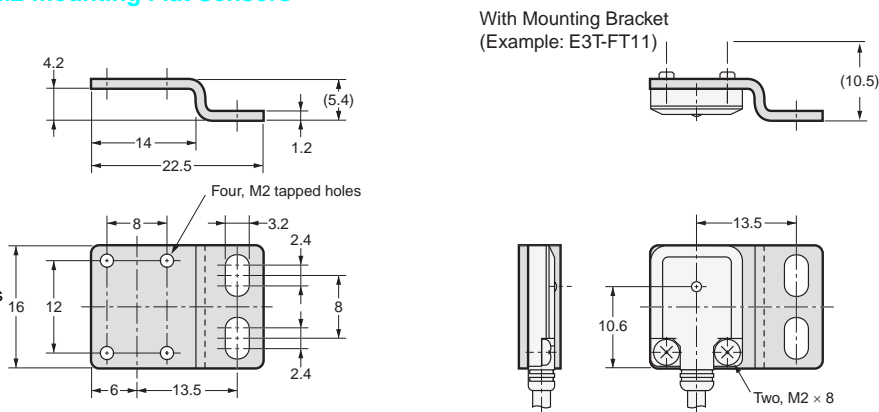

Mounting Bracket for M3-mounting Side-view Sensors

E39-L166



Material: 1.2-mm-thick stainless steel (SUS304)

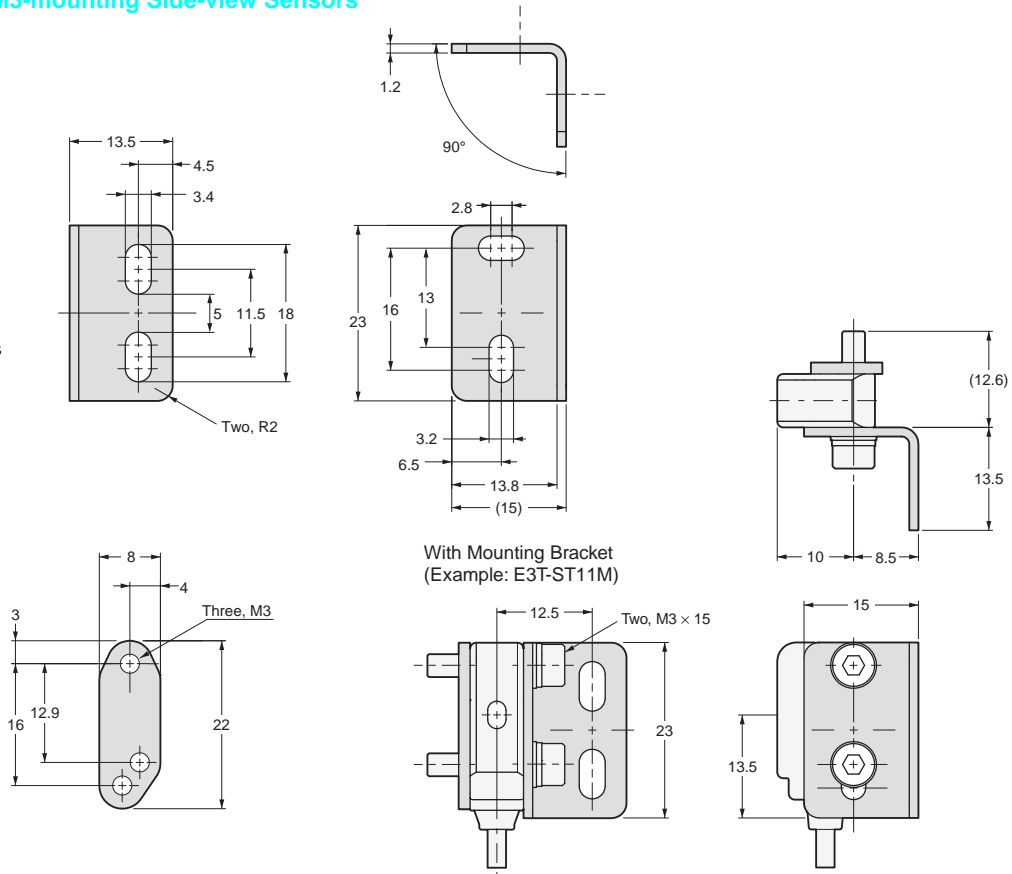

Mounting Bracket for M3-mounting Flat Sensors

E39-L167



Material: 1.5-mm-thick stainless steel (SUS304)

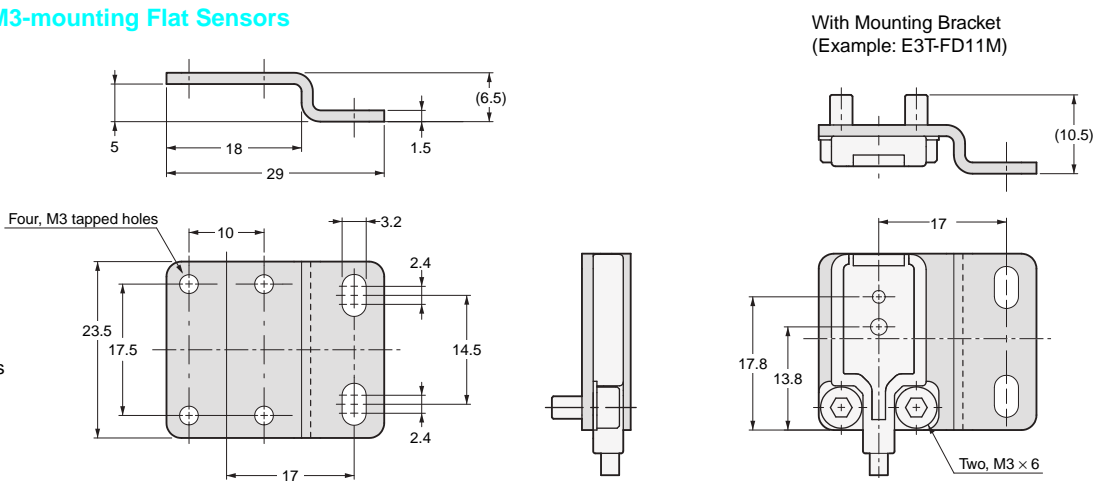

Back-mounting Spacer for M3-mounting Flat Sensors

E39-L168

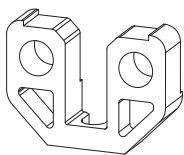

Material: PBT (polybutylene terephthalate)

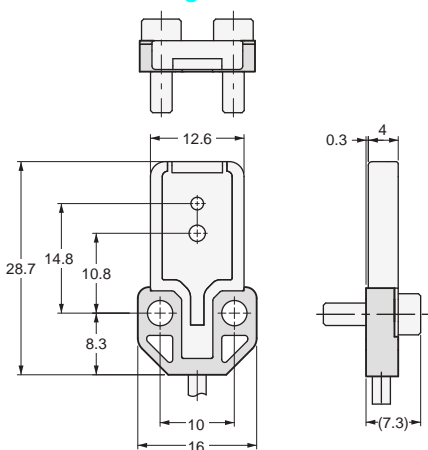

Note: Use this Spacer when mounting the Sensor from the back.

Terms and Conditions Agreement

Read and understand this catalog.

Please read and understand this catalog before purchasing the products. Please consult your OMRON representative if you have any questions or comments.

Warranties.

- (a) Exclusive Warranty. Omron's exclusive warranty is that the Products will be free from defects in materials and workmanship for a period of twelve months from the date of sale by Omron (or such other period expressed in writing by Omron). Omron disclaims all other warranties, express or implied.
- (b) Limitations. OMRON MAKES NO WARRANTY OR REPRESENTATION, EXPRESS OR IMPLIED, ABOUT NON-INFRINGEMENT, MERCHANTABILITY OR FITNESS FOR A PARTICULAR PURPOSE OF THE PRODUCTS. BUYER ACKNOWLEDGES THAT IT ALONE HAS DETERMINED THAT THE PRODUCTS WILL SUITABLY MEET THE REQUIREMENTS OF THEIR INTENDED USE.

Omron further disclaims all warranties and responsibility of any type for claims or expenses based on infringement by the Products or otherwise of any intellectual property right. (c) Buyer Remedy. Omron's sole obligation hereunder shall be, at Omron's election, to (i) replace (in the form originally shipped with Buyer responsible for labor charges for removal or replacement thereof) the non-complying Product, (ii) repair the non-complying Product, or (iii) repay or credit Buyer an amount equal to the purchase price of the non-complying Product; provided that in no event shall Omron be responsible for warranty, repair, indemnity or any other claims or expenses regarding the Products unless Omron's analysis confirms that the Products were properly handled, stored, installed and maintained and not subject to contamination, abuse, misuse or inappropriate modification. Return of any Products by Buyer must be approved in writing by Omron before shipment. Omron Companies shall not be liable for the suitability or unsuitability or the results from the use of Products in combination with any electrical or electronic components, circuits, system assemblies or any other materials or substances or environments. Any advice, recommendations or information given orally or in writing, are not to be construed as an amendment or addition to the above warranty.

See <http://www.omron.com/global/> or contact your Omron representative for published information.

Limitation on Liability; Etc.

OMRON COMPANIES SHALL NOT BE LIABLE FOR SPECIAL, INDIRECT, INCIDENTAL, OR CONSEQUENTIAL DAMAGES, LOSS OF PROFITS OR PRODUCTION OR COMMERCIAL LOSS IN ANY WAY CONNECTED WITH THE PRODUCTS, WHETHER SUCH CLAIM IS BASED IN CONTRACT, WARRANTY, NEGLIGENCE OR STRICT LIABILITY.

Further, in no event shall liability of Omron Companies exceed the individual price of the Product on which liability is asserted.

Suitability of Use.

Omron Companies shall not be responsible for conformity with any standards, codes or regulations which apply to the combination of the Product in the Buyer's application or use of the Product. At Buyer's request, Omron will provide applicable third party certification documents identifying ratings and limitations of use which apply to the Product. This information by itself is not sufficient for a complete determination of the suitability of the Product in combination with the end product, machine, system, or other application or use. Buyer shall be solely responsible for determining appropriateness of the particular Product with respect to Buyer's application, product or system. Buyer shall take application responsibility in all cases.

NEVER USE THE PRODUCT FOR AN APPLICATION INVOLVING SERIOUS RISK TO LIFE OR PROPERTY OR IN LARGE QUANTITIES WITHOUT ENSURING THAT THE SYSTEM AS A WHOLE HAS BEEN DESIGNED TO ADDRESS THE RISKS, AND THAT THE OMRON PRODUCT(S) IS PROPERLY RATED AND INSTALLED FOR THE INTENDED USE WITHIN THE OVERALL EQUIPMENT OR SYSTEM.

Programmable Products.

Omron Companies shall not be responsible for the user's programming of a programmable Product, or any consequence thereof.

Performance Data.

Data presented in Omron Company websites, catalogs and other materials is provided as a guide for the user in determining suitability and does not constitute a warranty. It may represent the result of Omron's test conditions, and the user must correlate it to actual application requirements. Actual performance is subject to the Omron's Warranty and Limitations of Liability.

Change in Specifications.

Product specifications and accessories may be changed at any time based on improvements and other reasons. It is our practice to change part numbers when published ratings or features are changed, or when significant construction changes are made. However, some specifications of the Product may be changed without any notice. When in doubt, special part numbers may be assigned to fix or establish key specifications for your application. Please consult with your Omron's representative at any time to confirm actual specifications of purchased Product.

Errors and Omissions.

Information presented by Omron Companies has been checked and is believed to be accurate; however, no responsibility is assumed for clerical, typographical or proofreading errors or omissions.

OMRON Corporation Industrial Automation Company
Tokyo, JAPAN

Contact: www.ia.omron.com

Regional Headquarters

OMRON EUROPE B.V.

Sensor Business Unit

Carl-Benz-Str. 4, D-71154 Nufringen, Germany
Tel: (49) 7032-811-0/Fax: (49) 7032-811-199

OMRON ELECTRONICS LLC

One Commerce Drive Schaumburg,
IL 60173-5302 U.S.A.
Tel: (1) 847-843-7900/Fax: (1) 847-843-7787

OMRON ASIA PACIFIC PTE. LTD.

No. 438A Alexandra Road # 05-05/08 (Lobby 2),
Alexandra Technopark,
Singapore 119967
Tel: (65) 6835-3011/Fax: (65) 6835-2711

OMRON (CHINA) CO., LTD.

Room 2211, Bank of China Tower,
200 Yin Cheng Zhong Road,
PuDong New Area, Shanghai, 200120, China
Tel: (86) 21-5037-2222/Fax: (86) 21-5037-2200

Authorized Distributor:

© OMRON Corporation 2010-2020 All Rights Reserved.
In the interest of product improvement,
specifications are subject to change without notice.

CSM_6_5
Cat. No. E407-E1-03

Printed in Japan
0720 (1010)